

Tango^{Plus}

Sound Level Meter class 1 according IEC 61672-1:2014

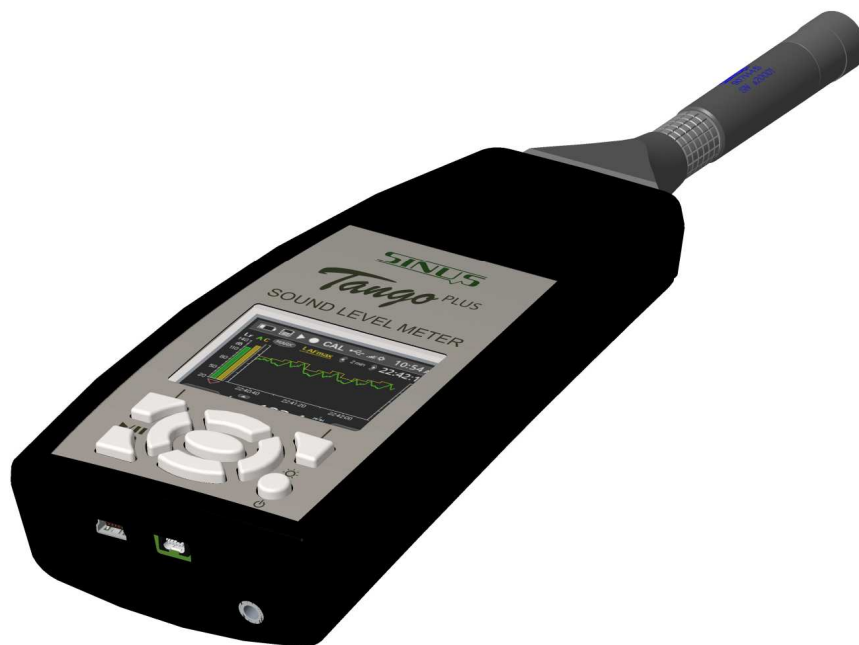

Version 2.51

June 13, 2019

© SINUS Messtechnik GmbH
Foeppelstrasse 13, 04347 Leipzig, Germany

<http://www.soundbook.de>

info@soundbook.de

© **SINUS Messtechnik GmbH**

All rights reserved. No part of this manual may be reproduced, stored in a retrieval system or transmitted, in any form or by any means, electronic, mechanical, photocopying, recording or otherwise, without the prior written permission of SINUS Messtechnik GmbH. We reserve the right to alter the contents of this manual without prior notice. SINUS Messtechnik GmbH accepts no responsibility for technical or typographical errors or deficiencies in this manual. Furthermore, SINUS Messtechnik GmbH disclaims all liability for damage occurring directly or indirectly as a result of the delivery, performance or usage of this material.

All products or services mentioned in this document are the trademarks or service marks of their respective companies or organizations.

Contents

1 Design	5
1.1 General information	5
1.2 Important notes	6
1.3 Power supply	6
1.3.1 Replace batteries	6
1.4 Design	7
1.4.1 Keypad	8
1.4.2 Display	8
1.5 First use	9
1.6 Calculated values	10
1.6.1 Calculated sound levels	10
1.6.2 Calculated spectra	10
1.7 Software installation	11
1.7.1 Tango_Plus driver installation	11
1.7.2 Tango-Utilities installation	11
2 Appliance	12
2.1 Operating mode	12
2.2 Device configuration	12
2.2.1 Manual configuration	12
2.3 Tango-Utilities	14
2.3.1 Status bar	14
2.3.2 Program settings and Extended device settings	14
2.3.3 Info Tab	15
2.3.4 Setup Tab	15
2.3.5 Display Tab	17
2.3.6 Octave Tab	17
2.3.7 Data-Tab	18
2.3.8 Data export	19
2.4 Calibrate	21
2.4.1 Calibrate using Tango-Utilities	21
2.4.2 Calibrate Tango_Plus directly	22
2.5 Measure	23
2.5.1 Measure low sound levels	23
2.5.2 Overload and Underrange	23
2.5.3 Calibrated Measurement	23
2.5.4 View measurement results on Tango_Plus	24
2.5.5 Print results	24
3 Information for type approval	25
3.1 Configuration as classical handheld level meter	25
3.1.1 Frequency response of Tango_Plus - Configuration SLM	25
3.1.2 Directional characteristics - Configuration SLM	26
3.1.3 Corrections according to case reflections - Configuration SLM with connected microphone	27
3.2 Configuration with weather protection - Outdoor Kit	29
3.2.1 Weather Protector SWS1	29
3.2.2 Frequency response of the microphone - Configuration Outdoor Kit	32
3.2.3 Directional characteristics - Configuration Outdoor Kit	33

3.2.4	Corrections for the use of the weather protector	36
3.3	Configuration for electrical test	37
3.3.1	Frequency response of the microphone - Configuration for electrical test	37
3.3.2	Details on EMC	38
3.3.3	EMC test	38
3.3.4	Mains frequency and high-frequency fields	38
3.4	Effect of environmental conditions	39
3.4.1	Effect of mechanical vibration	39
3.5	Self-generated noise	40
3.6	Linear operating ranges	40
3.6.1	Level linearity range	40
3.7	Frequency weighting	41
3.8	Verifiable Firmware	41
4	Technical specifications	42
4.1	Microphone with capsule MK255	43
4.1.1	Random incidence and free-field correction	44
4.1.2	Connection assembly of the detachable microphone	44
4.2	Optional Accessories	45
4.3	Technical specifications of the calibrators	45
5	Declaration of Conformity	46
	INDEX	47

ATTENTION! The detachable microphone must be used only together with the matched Tango_Plus! The capsule MK255 and the preamplifier (Order number: 907144.5) are selected as pair by manufacturer and must **not** be deviated! If used with other hardware with more than ± 2.5 V power supply, the preamplifier will be damaged and warranty is lost!

1 Design

Thank you for choosing the product Tango_Plus by SINUS Messtechnik GmbH. Please read this manual carefully before using the measuring system. Tango_Plus is an integrating sound level meter designed according to IEC 61672-1:2014, accuracy class 1 and immunity to interference group Z. It can measure also 1/1 and 1/3 octaves according to IEC 61260:2003. This is true for all configurations described in section 3.

NOTICE! Tango_Plus may perform measurements that require an official verification of the calibration and that are legally binding.
(type approval applied)

ATTENTION! If Tango_Plus is used for legally binding measurements, only original accessories shall be used.

We recommend you to perform several test measurements to get familiar with the instrument before using it for important measuring tasks.

1.1 General information

The manual includes the following signs to indicate important information:

NOTICE! These are information on the efficient use and correct handling of the analyzer as well as additional information.

CAUTION! These instructions shall avoid any hardware damages or dangers for users.

ATTENTION! These instructions shall avoid any measurement mistakes, hardware damages etc.

Please feel free to contact us for any questions on the functionality and operation of the instrument. Direct your questions or requests on spare parts and accessories to the following address:

Address: SINUS Messtechnik GmbH
Föppelstraße 13
04347 Leipzig, Germany

Telephone: +49-(0)341-24429-33
Fax: +49-(0)341-24429-99
E-mail: info@soundbook.de
Web: <http://www.soundbook.de>

1.2 Important notes

When measuring with the device, please consider the following notes:

- Use the device as described in this manual only.
- Despite of its robust design, protect the device from any unnecessary bumps and vibrations as well as humidity and dirt.
- Do not touch or moisten the sensitive microphone membrane during work.
- Pay attention to the permissible temperatures for using the device.
- Always switch off the device after using.
- Do not expose the device to excess temperature as for example in a car with direct sunlight.
- If necessary, clean the device carefully without using solvents.
- Do not disassemble the device. Do not try to repair the device in case of malfunction. Such manipulation will always cause the loss of warranty and major damages. Make a note of the occurring errors and send us the device for repair.

1.3 Power supply

Tango_Plus is powered by two batteries of the type LR6/AA (nominal voltage 1.2 . . . 1.5 V, primary cell or rechargeable). So it can run for at least 40 hours. Via the according USB cable Tango_Plus can be powered auxilliarily by an external source, but batteries must always be inserted. For that the cable has to be connected to a PC or to the public power supply via a suitable adapter. The USB access is totally separated from the internal batteries, so that the batteries are not affected, but accumulators are not recharged, too.

ATTENTION! For legally binding measurements Tango_Plus has to be powered by battery, disconnected from the public power supply.

1.3.1 Replace batteries

The battery compartment is located on the back at the bottom of the device (figure 1.1).

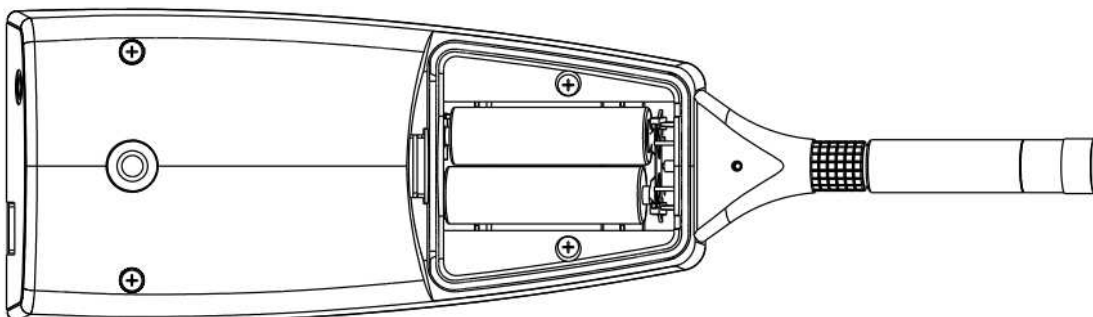

Figure 1.1: Open battery compartment

Follow the instructions below to replace the batteries:

- Move up the lock of the battery compartment.

- Remove the lid.
- Remove the discharged batteries.
- Insert the new batteries paying attention to the polarity (figure 1.1)
- Switch on the device and check the battery status on the display (figure 1.4.2).

ATTENTION! Changing the batteries causes loss of time, if Tango_Plus is not connected to external power supply at the same time.

1.4 Design

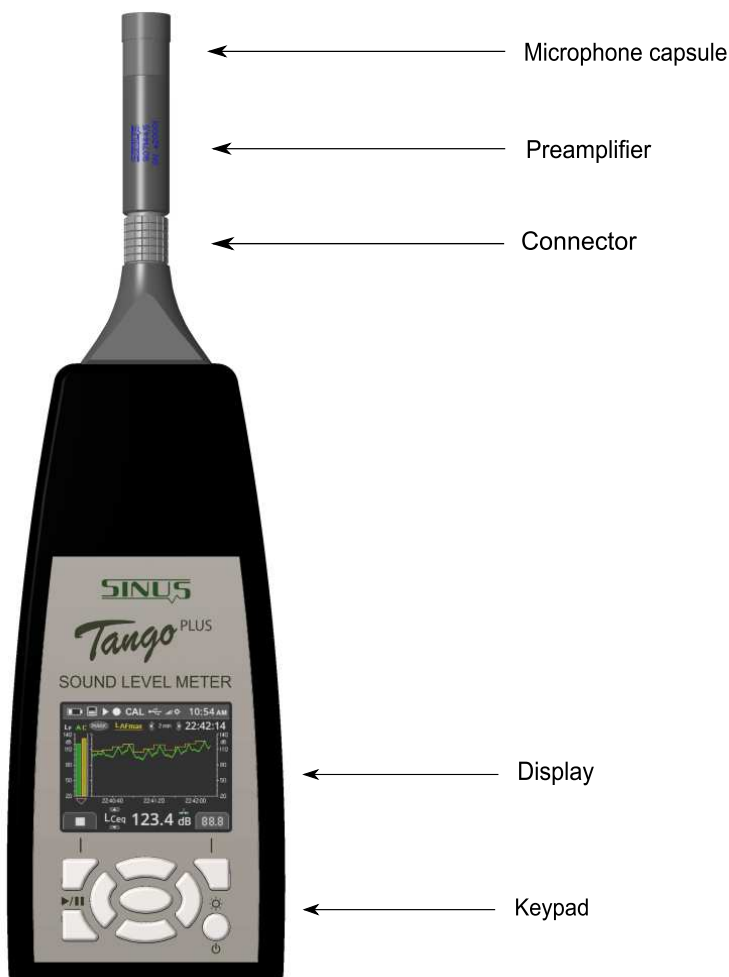

Tango_Plus contains the following parts: detachable microphone with preamplifier, casing, display, keypad and battery compartment. Opening the device is only necessary for replacing the batteries (figure 1.3.1).

At the bottom of the device the USB socket is located for connecting the device to a PC (type USB-C). Next to it there is a socket for a 3.5 mm stereo jack. This monitoring output is used to connect a headset for example, it is *not* approved for legally binding measurements. Furthermore Tango_Plus provides a socket to connect a printer directly (section 2.5.5).

A detailed description of the display and keypad is given in the paragraphs 1.4.2 and 1.4.1. Pay also attention to the notes given in paragraph 1.2.

Figure 1.2: Design of the device

ATTENTION! For legally binding measurements Tango_Plus has to be powered only by battery. The monitoring output is not approved for this.

1.4.1 Keypad

If the device is not controlled via PC, you may also use the keypad for setup. In the middle it contains arrow keys with an OK-button in the center. The top corners contain function keys, whose functions are indicated by symbols on the display. The key below on the left is used to start and pause measurements, while the one on the right switches on the device and toggles the brightness level.

1.4.2 Display

The display shows the measured values and is used for setting up the device. It is refreshed every 500 ms. The status bar on the top of the display shows symbols for: Battery, Memory, Play/Pause, Storage, Calibration, USB connection, Level of brightness and time. Below the clock time the measuring time is displayed. There are three basic modi to display spectra, history data or numeric values as well as a display for information:

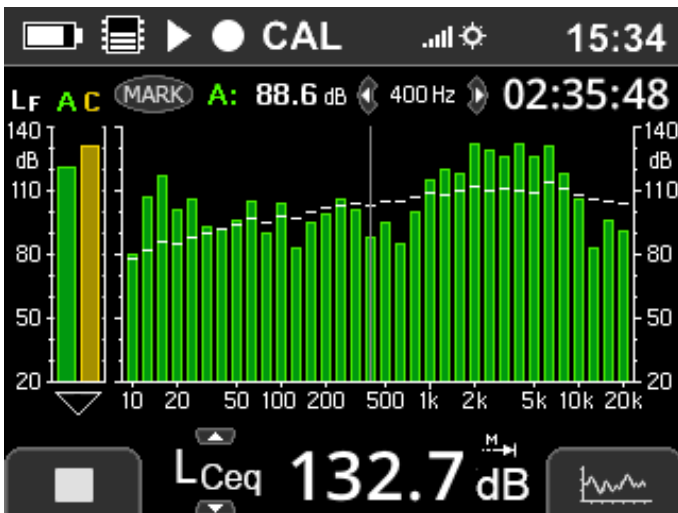

Figure 1.3: Third Octave Display

The Third Octave Display shows a spectrum in the main part with live values as bars and L_{eq} values as roof top. Via left/right keys the spectral cursor can be moved to select single bands. The band level and the frequency are displayed above the graph as well as the measurement duration. On the left L_{AF} and L_{CF} are displayed as bars. The bottom shows numerically one sound level value, which can be switched using the up/down keys.

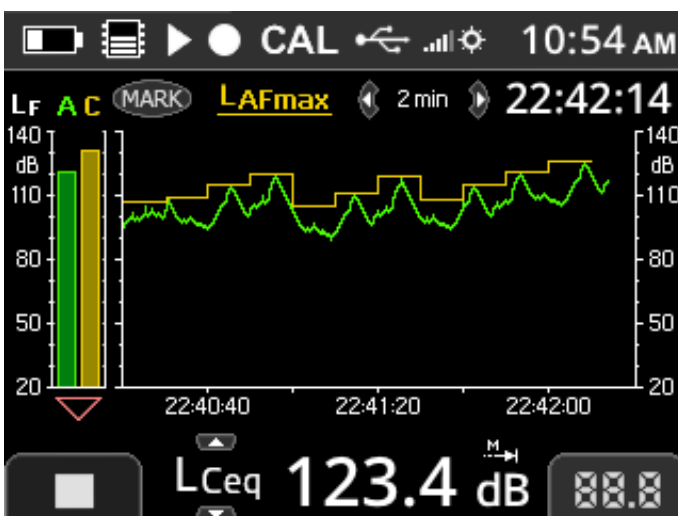

Figure 1.4: History Display

Instead of a spectrum the History Display shows two level graphs in the main part. Which levels are shown is set in the configuration (section 2.2.1). The time length of the x-axis can be toggled with the left/right keys.



Figure 1.5: Numeric Display

The Numeric Display shows the value of the levels selected at the bottom.

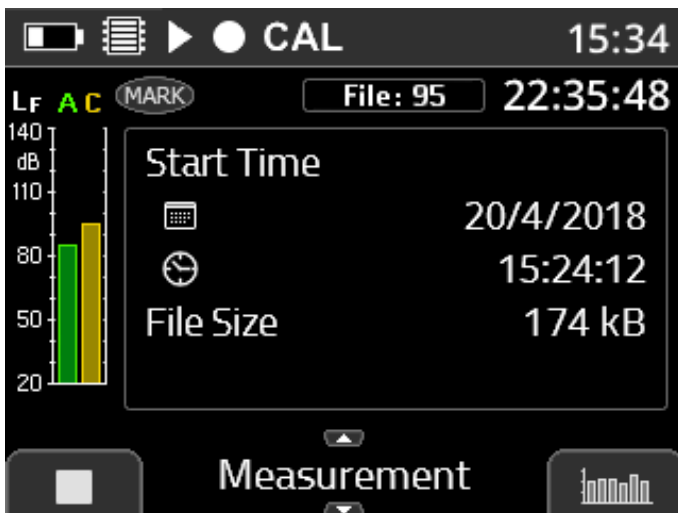

Figure 1.6: Info Measurement

The Info Display shows information on tabs for:

- Measurement: Name, Date, Duration, Time and File size
- Microphone: Calibration date, time and status as well as sensitivity and microphone connection mode (section 3.1 and 3.2)
- Hardware: Firmware version, Hardware revision, serial numbers of Pre-amplifier and Microphone capsule (see also table 2.2 : Device > Info)

NOTICE!

A warning appears, if the original preamplifier is not detected. A Measurement can still be performed, but an according remark is connected with it.

1.5 First use

Pay attention to the following notes before using the device for the first time:

- Read carefully the manual and follow the instructions before using the device.
- Insert the batteries as described in section 1.3.1.
- Install the required software on a PC (driver and **Tango-Utilities**).
- Connect the device with the PC using the supplied USB cable.
- Switch on the device by pressing the On/Off-Button (minimum 3 seconds).

1.6 Calculated values

Tango_Plus can calculate several sound levels as well as full and 1/3 octaves. Data can be stored up to an amount of 32 MB.

1.6.1 Calculated sound levels

Level	Description
L_{AF}	Sound pressure level, frequency weighting A, Fast (125 ms time constant)
L_{AFmax}	Level maximum of L_{AF} for the entire measuring period (on the display) or of the last storing interval (stored data)
L_{AFmin}	Level minimum of L_{AF} for the entire measuring period (on the display) or of the last storing interval (stored data); only available by Tango-Utilities .
L_{AS}	Sound pressure level, frequency weighting A, Slow (1 s time constant)
L_{ASmax}	Level maximum of L_{AS} for the entire measuring period (on the display) or of the last storing interval (stored data)
L_{ASmin}	Level minimum of L_{AS} for the entire measuring period (on the display) or of the last storing interval (stored data); only available by Tango-Utilities .
L_{CF}	Sound pressure level, frequency weighting C, Fast (125 ms time constant)
L_{CFmax}	Level maximum of L_{CF} for the entire measuring period (on the display) or of the last storing interval (stored data)
L_{CFmin}	Level minimum of L_{CF} for the entire measuring period (on the display) or of the last storing interval (stored data); only available by Tango-Utilities .
L_{AImax}	Maximum sound impulse level, frequency weighting A
L_{Cpeak}	Peak value of the C-weighted sound pressure level
L_{Apeak}	Peak value of the A-weighted sound pressure level
L_{Aeq}	Equivalent continuous sound pressure level for the entire measuring period (on the display) or of the last storing interval (stored data), frequency weighting A
L_{Ceq}	Equivalent continuous sound pressure level for the entire measuring period (on the display) or of the last storing interval (stored data), frequency weighting C
$L_{Ceq} - L_{Aeq}$	Difference of the values L_{Ceq} and L_{Aeq}
L_{AE}	Sound exposure level, frequency weighting A
L_{AFT}	Maximum L_{AF} of the last 5 s interval.
L_{AFTeq}	Equivalent continuous sound pressure level calculated from the L_{AFT} levels during the entire measuring period according to DIN 45645-1
$L_{AFTeq} - L_{Aeq}$	Difference of the values L_{AFTeq} and L_{Aeq}
L_{AImeq}	Equivalent continuous sound impulse level, frequency weighting A
$L_{AImeq} - L_{Aeq}$	Difference of the values L_{AImeq} and L_{Aeq}
$L_{Cpeak>n}$	Time in which the L_{Cpeak} exceeded n dB
L_{AFn}	Percentile levels can be calculated from the L_{AF} ($n = 1, 2, 3$). There are 7 standard percentiles (1, 5, 10, 50, 90, 95, 99), but also user defined percentiles are possible.

Table 1.1: Calculated sound levels

NOTICE!

All sound level values may only be reset by manual Start/Stop operation and the integration time for the equivalent continuous sound pressure levels may only be set with this operation.

NOTICE!

All integrated sound levels listed in table 1.1 can be displayed on the device immediately after finishing a measurement/integration.

1.6.2 Calculated spectra

Tango_Plus can calculate full and 1/3 octaves. A, C or Z weighting may be applied. The frequency range is: 10 Hz - 20 kHz. The storage interval defines the number of individual spectra, that are linear averaged.

1.7 Software installation

First TANGO driver must be installed for that Tango_Plus is recognized via USB connection. Second **Tango-Utilities** should be installed for configuration of Tango_Plus settings and export of data.

1.7.1 Tango_Plus driver installation

Please follow the instructions below to install the TANGO driver on a PC. You find the file on the enclosed USB stick. Use the Windows Explorer to start the driver installation programme. Perform the install setting and confirm always. Depending on the system performance this procedure may take a few minutes.

1.7.2 Tango-Utilities installation

Installing the software **Tango-Utilities** resembles the installation procedure of most Windows applications. Follow the instructions below:

- Run the installation program (*Tango_Utilities_Version.exe*).
- The first window shows the software version. Click on **Next** to continue to the next window.
- Set the installation directory in the next window. Click on **Next** to continue to the next dialog.
- In this dialog you may specify the directory in the Windows Start Menu. Click on **Next** to continue to the next dialog.
- This dialog summarizes your settings. Click on **Install** to confirm and continue.
- Finish the installation by clicking on **Finish**.

2 Appliance

2.1 Operating mode

Tango_Plus offers different operating modes:

OFF The device is off and no measurements can be performed. Only the clock is running inside.

Stop The device is running. The L_{AF} and the L_{CF} are measured and displayed. If Record mode is enabled, the circle symbol ● is displayed.

NOTICE! The time between STOP and a possible new measurement is: 16 ms.

Run The device is on and measuring (▶ is blinking). If data recording has been activated, data will be stored (● is blinking). You may read the instantaneous measurement values on the display and move between the values using the Up/Down keys.

Pause A running measurement is paused (|| is displayed) and so the measuring time. The measurement can be stopped or proceeded any time.

Repeat If a duration is specified and repeat mode enabled, the so configured measurement is repeated in the specified interval.

Start Time A measurement is configured, but waiting with record for the specified time (⊕ is blinking). The device can be shut down. It will wake up automatically to perform the measurement and shut down afterwards again. The measurement can be stopped any time.

Display	Description
	The device is in Pause-Mode. The measurement has been paused and the measuring time has been stopped.
●	Data recording is active. The measured data will be stored in Run-Mode.
▶	The device is in Run-Mode (Symbol blinks). The measurement has been started. If data recording is active, the measured data are stored. If data recording is inactive, no data will be stored.
⊕	A measurement is configured, but waiting with record for the specified time (symbol is blinking). When the measurement is running, the symbol stops blinking.

Table 2.1: Display of run modes

NOTICE! The setting for automatic start time can only be configured manually on the device.

2.2 Device configuration

You may configure the device manually or via PC using the software **Tango-Utilities**.

2.2.1 Manual configuration

The manual configuration of the device without PC is shown in the following table 2.2:

Item	Description
Measurement	
Record Mode	Select values to be stored or just displayed.
Sync at Full Hour	Synchronize time intervals to full hours.
Fixed Duration	Measurement ends after a fixed time.
Repeat Mode	If a Fixed Duration is specified an automatic repeat can be enabled.
Repeat Interval	If a Fixed Duration is specified and the Repeat Mode is enabled, an interval must be configured in which the measurement is repeated. So can be configured for example to measure every day for 1 hour at 6 o'clock.
Start Time	Predefine a time to start the measurement automatically.
Calibration	
Start Calibration	Start the process of calibration.
Calibration Level	Set the calibration level (94.0 dB, 104.0 dB, 114.0 dB, Other).
Reset Calibration	Reset the calibration level to factory value.
Measurement Values (Select a sound level e.g. L_{AFmax} and adjust the following properties.)	
Display Location	Select on which graph the value shall be shown.
Display Interval	Select the rate of display refresh (500 ms, . . . , 60 min, End Result only).
Storage Interval	Set the storage interval (No storage, 62.5 ms, . . . , 60 min, End Result only).
Print Result	Decide whether the result shall be printed.
Octave Spectrum	
Octave Mode	Select whether 1/3 or full octaves shall be measured.
Display Range	Adjust the scaling of the Y-axis.
Display Weigthing	Available weighings: Z, A, C
Display Interval	Select the rate of display refresh (125 ms, . . . , 60 min, End Result only).
Storage Weigthing	Available weighings: Z, A, C
Storage Interval	Set the storage interval (No storage, 125 ms, . . . , 60 min, End Result only).
History Graph	
Display Range	Adjust the scaling of the Y-axis.
History Time	Adjust the scaling of the X-axis.
Graph 1	Select which value shall be displayed as yellow.
Graph 2	Select which value shall be displayed as green.
Storage Files	
Stored Files	View Results, Delete File
Reset Storage File ID	Resets File ID to the smallest possible number, so that no gaps are filled with new measurements: Assume stored measurements are labeled with IDs 1 to 6. If for example measurements 3, 5, and 6 are deleted and the File ID is reset, the next measurement will be labeled with the number 5.
Erase all Storage Files	Clear all Files.
Device	
Time	Set time and select 12h or 24h format.
Display	Set Display properties.
Panels	Set, whether Panels should be displayed or not: Octave Spectrum, History Graph, Results, Measurement Info
Options	Additional configurational settings: Microphone Connection (Direct connection, cable connection, Weather Protector) Power (automatic: On by USB, On by Reset, Off by Inactivity)
Info	Provides information about firmware and hardware (see also figure 1.6).
Reset Configuration	Reset to factory settings.
Print Results	

Table 2.2: Manual configuration menu of Tango_Plus

2.3 Tango-Utilities

Tango-Utilities is the basic software to configure Tango_Plus and export values from measurements. It is not meant to perform further analysis calculations. For configuring the device via PC, you have to install the Tango-Driver and **Tango-Utilities** software first (section 1.7). **Tango-Utilities** contains a line for main menu and a line with buttons for: Stop, Run/Pause, Store/Not Store, Set Marker and start calibration. At the bottom the Tabs are located and the status bar.

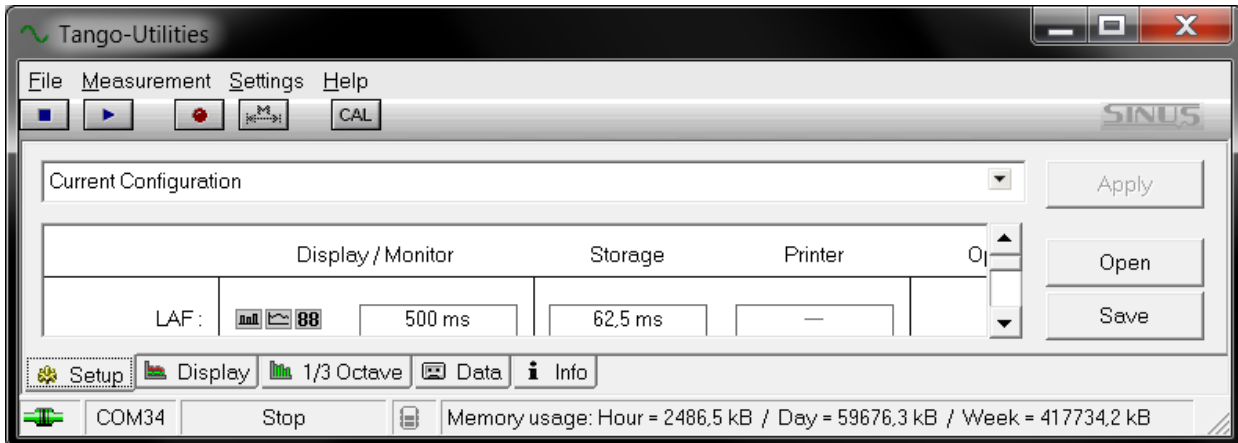

Figure 2.1: **Tango-Utilities** view: Main menu, buttons, working area, Tabs, Status bar

2.3.1 Status bar

The **status bar** displays various status information from left to right:

Connection Status: disconnected, connected, but Tango_Plus off, connected, Tango_Plus on;

Virtual COM Port:

Measurement Status: Stop, Measurement, Pause;

Record Status: Record-Mode off, Record-Mode on, *blinking* Record-Mode on (Recording);

Marker Status: MARK;

Memory usage: per Hour, Day and Week

2.3.2 Program settings and Extended device settings

Via the main menu **Settings->Program...** the following settings are available (figure 2.2): Selection of the connected device Tango_Plus (**Connected Device**), default export directory (**Default Export Directory**) and the default directory for configuration data. The Extended device settings *cannot* be adjusted manually without PC.

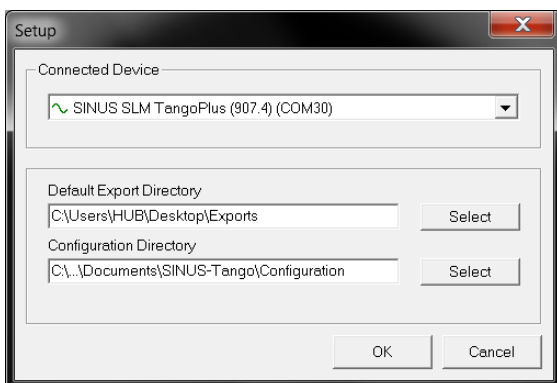

Figure 2.2: **Tango-Utilities** - Program settings

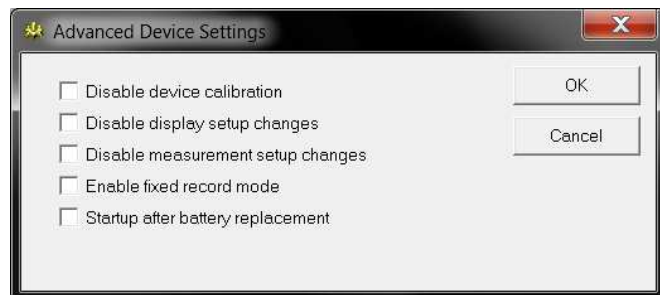

Figure 2.3: **Tango-Utilities**- Extended device settings

Parameter	Description
Disable Device Calibration	Select this parameter to disable calibration feature on the device.
Disable display setup changes	Select this parameter to lock the display settings.
Disable measurement setup changes	Select this parameter to lock measurement recording settings.
Enable fixed record mode	Select this parameter to activate the Record-Mode permanently.
Startup after battery replacement	Automatic start of Tango_Plus after changing the batteries.

Table 2.3: Extended program settings

2.3.3 Info Tab

You may view the software version of **Tango-Utilities** in the main menu selecting **Help -> About** (figure 2.5). The firmware version of the device is displayed in the Info-Tab (figure 2.4).

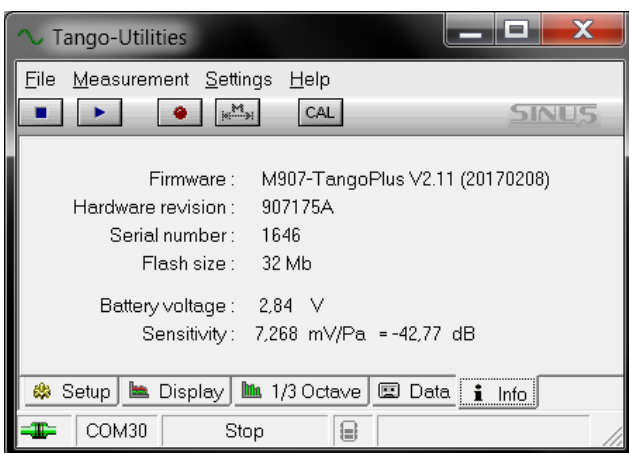

Figure 2.4: **Tango-Utilities** - Info Tab



Figure 2.5: **Tango-Utilities** - About-Box

2.3.4 Setup Tab

The Setup tab of **Tango-Utilities** (figure 2.6) provides the configuration of Tango_Plus for a measurement. In the column **Display** use the check boxes to enable individual values and comboboxes to set the graphic refresh rate for display. Several values offer optional parameters, which you may set in the column **Options**. By the buttons **Open** and **Save** you may open a configuration from the PC or save the current one to it. The same can be done by using the menu points **File** → **Open Configuration** and **File** → **Save Configuration As**. The current configuration is transmitted to Tango_Plus by clicking on **Apply**.

In the column **Storage** the correspondig storage conditions are adjusted. The storage can be turned off, limited to one finish result or done in regular intervals. For the interval time span several values are provided from 62,5 ms up to 60 min depending on the measurement value. Even if the interval storage is selected a finish result over the whole measurement time is calculated and stored additionally. This would always be saved, even if the intervall storage would have been aborted because of full memory. In this case the record symbol ● would stop blinking.

NOTICE! For the interval storage of the percentiles only the same interval time span can be selected.

If **Synchronisation** is enabled, the interval storage will be synchronised with the full hours of day time. So every full hour the current interval is closed and a new one is started. The clock is set every time, when connecting Tango_Plus to **Tango-Utilities**.

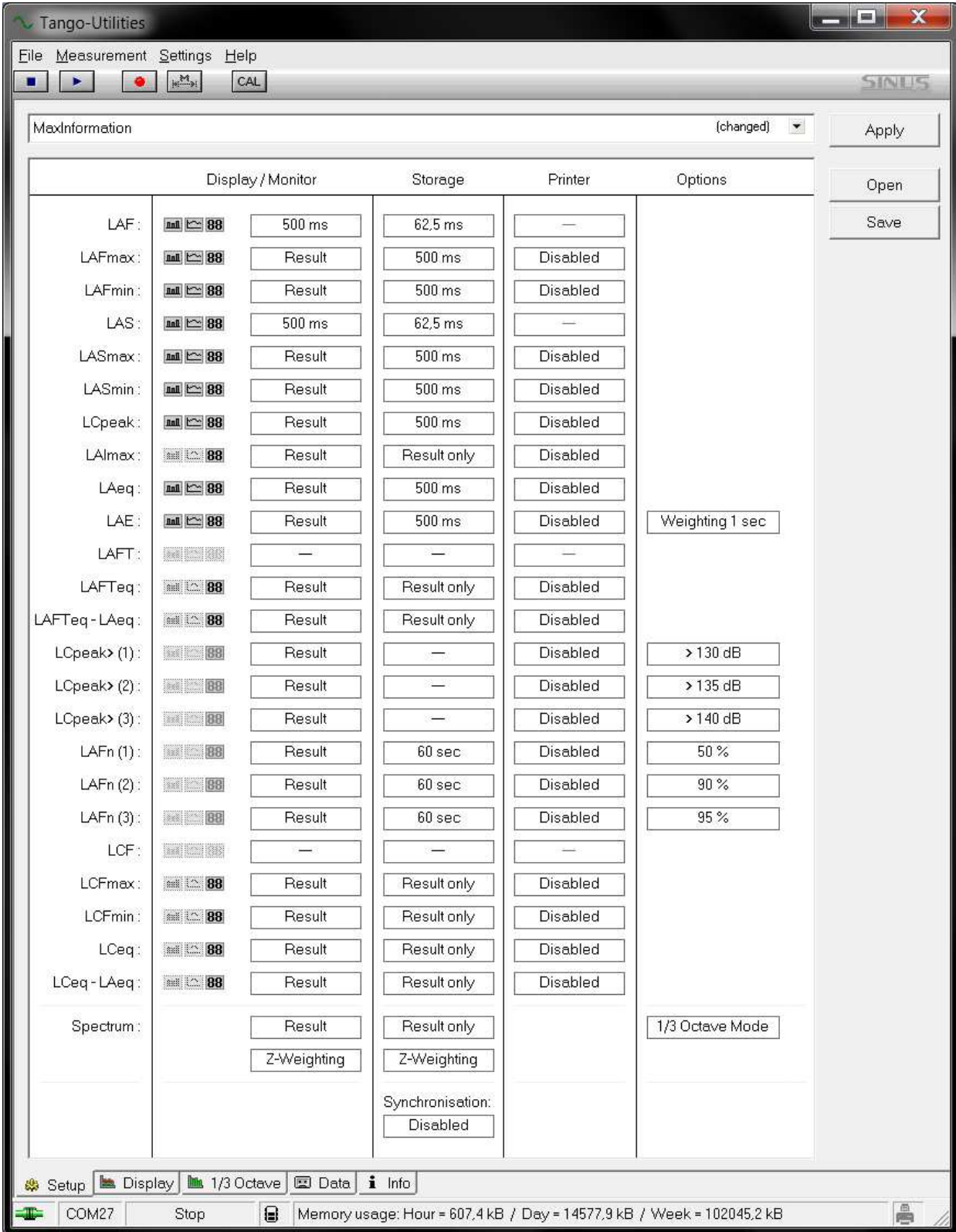

Figure 2.6: Configuration in setup tab

2.3.5 Display Tab

In the Display tab history values are shown (figure 2.7), which are calculated by the device during a measurement (according to the settings in the Setup-Tab). On the left side you will find a table of values which can be displayed. You may select a maximum of four values for simultaneous display. The context menu of the graph provides Zoom and axes scaling functionality.

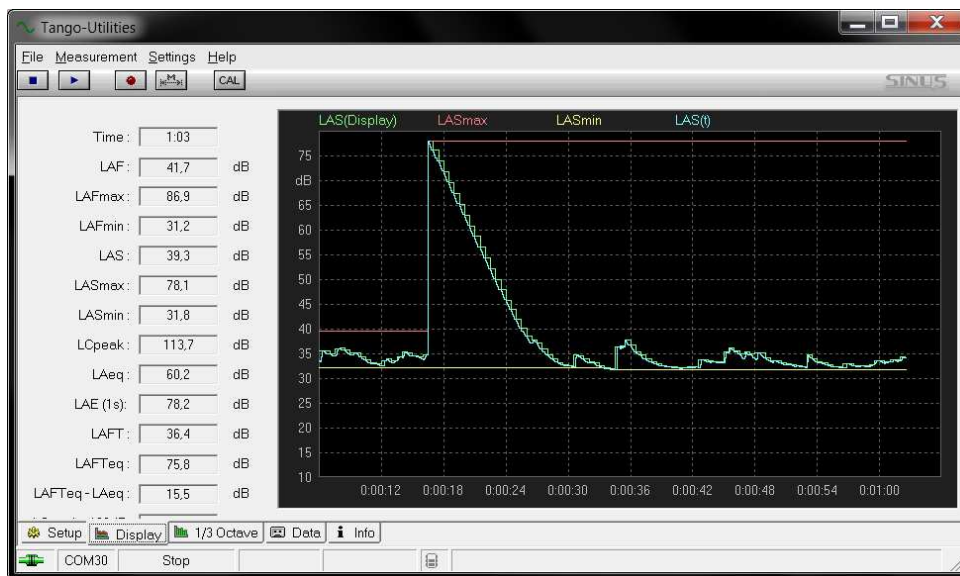

Figure 2.7: Show history values in Display Tab

2.3.6 Octave Tab

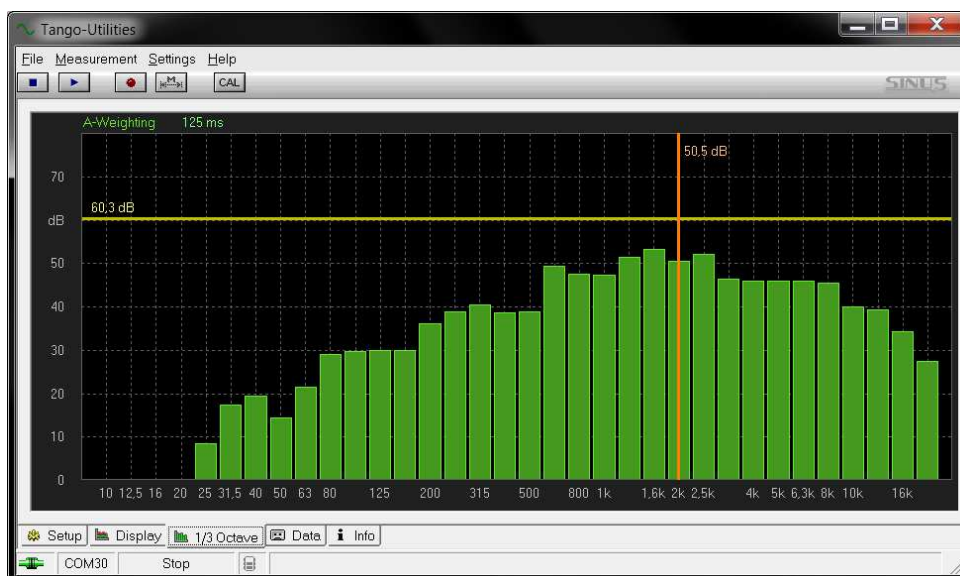

Figure 2.8: Show spectral values in Octave Tab

In the “1/3 Octave” tab spectral values are shown (figure 2.8), which are calculated by the device during a measurement (according to the settings in the Setup-Tab). To adjust weighing (Z-blue, A-green, C-yellow) or refresh rate for graphical display click on the corresponding items in the header of the graph. The context menu of the graph provides scaling functionality. Also displayed is a coordinate cross. The vertical line shows the current value of the selected band while the horizontal line shows the sum value.

2.3.7 Data-Tab

On the right side of the Data-Tab (figure 2.9) a table containing the recorded files is displayed. On the left side a summary of the selected measurement is displayed. By right-clicking on an entry in the table you will open a context menu in which you may delete the measurement (**Delete**) or export data (**Export**).

File info

File38
 Created : 20.07.2017 11:16:52
 Duration : 3:38
 Size : 127,46 KB

Overrange : no
 Underrange : no
 LAFmax : 70,9 dB
 LAFmin : 36,0 dB
 LASmax : 63,9 dB
 LASmin : 37,0 dB
 LCpeak : 94,3 dB
 LAImax : 73,7 dB
 LAeq : 51,7 dB
 LAE (1s) : 75,1 dB
 LAFTeq : 61,2 dB
 LAFTeq - LAeq : 9,5 dB
 LCpeak >130 dB : 0:00
 LCpeak >135 dB : —
 LCpeak >140 dB : —
 LAF90 : 37,4 dB
 LAF95 : —
 LAF99 : —
 LCFmax : 82,7 dB
 LCFmin : 47,5 dB
 LCeq : 62,6 dB
 LCeq - LAeq : 10,9 dB

Synchronisation : Disabled

Measurement	Start time	Size	Status
File1	13.06.2017 17:12:22	5 KB	New
File3	14.06.2017 09:59:19	2 KB	New
File4	14.06.2017 10:04:45	2 KB	New
File5	14.06.2017 10:12:21	1 KB	New
File6	14.06.2017 10:15:26	103 KB	New
File7	14.06.2017 10:57:43	2 KB	New
File8	14.06.2017 16:51:45	1 KB	New
File9	14.06.2017 16:51:56	3 KB	New
File10	14.06.2017 17:08:12	3 KB	New
File12	19.06.2017 09:40:55	2 KB	New
File13	20.06.2017 10:18:50	5 KB	New
File14	20.06.2017 10:19:20	1 KB	New
File15	03.07.2017 09:09:07	1 KB	New
File16	03.07.2017 09:09:33	2 KB	New
File17	03.07.2017 09:10:49	2 KB	New
File18	03.07.2017 09:11:04	2 KB	New
File19	03.07.2017 09:11:31	1 KB	New
File20	03.07.2017 09:11:57	1 KB	New
File21	03.07.2017 09:22:58	1 KB	New
File22	03.07.2017 09:23:06	1 KB	New
File23	04.07.2017 08:27:13	2 KB	New
File24	04.07.2017 10:09:19	3 KB	New
File25	04.07.2017 10:16:30	3 KB	New
File26	04.07.2017 10:17:07	3 KB	New
File27	04.07.2017 10:17:27	3 KB	New
File28	04.07.2017 10:17:48	1 KB	New
File29	17.07.2017 11:14:04	1 KB	New
File30	19.07.2017 13:03:22	204 KB	Exported
File31	19.07.2017 13:25:37	7 KB	New
File32	19.07.2017 13:27:00	270 KB	Exported
File33	19.07.2017 15:01:08	16 KB	New
File34	19.07.2017 15:02:24	6 KB	New
File35	19.07.2017 15:03:48	18 KB	New
File36	20.07.2017 11:09:19	101 KB	New
File37	20.07.2017 11:16:03	8 KB	New
File38	20.07.2017 11:16:52	128 KB	New

Setup Display 1/3 Octave Data Info

COM27 Stop Free memory: 22.8 Mb / 91 Files

Figure 2.9: Data Tab

ATTENTION! Maximum 128 files can be stored!

2.3.8 Data export

Measured data are saved to the internal storage of the device (32 MB). The data sets are listed in the Data-Tab (section 2.3.7). By right-clicking you may open a context menu, that provides access to the Export window (figure 2.10).

History Data tab

This tab provides the export of time histories of level or spectra to the Excel compatible csv format. To use it, check the “Enable Export file” box. You may specify the name, check automatic attributes to be given to the export file name and select the values, which that file should contain. Via the **Add File** button, you can create more History Data tabs, to get several different configured export files from the same measurement in the same export process.

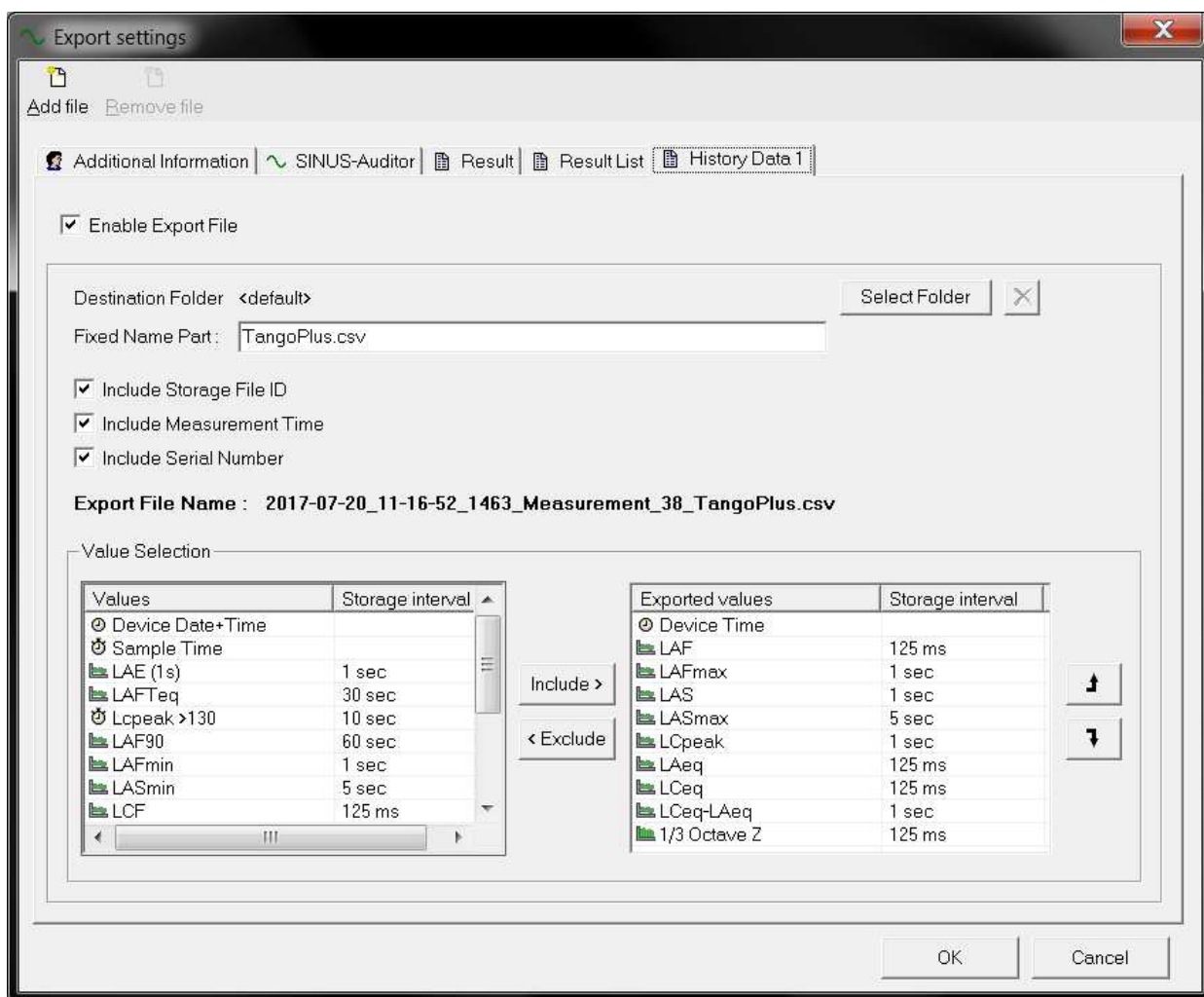

Figure 2.10: Export - History Data

NOTICE! If the set intervals do not fit exactly into the hourly grid for a synchronized measurement, the data of the last interval will be marked accordingly.

Result List tab

Enable this way of export to collect Endresults of all exported measurements in csv format. The configuration is similar to the History Data tab.

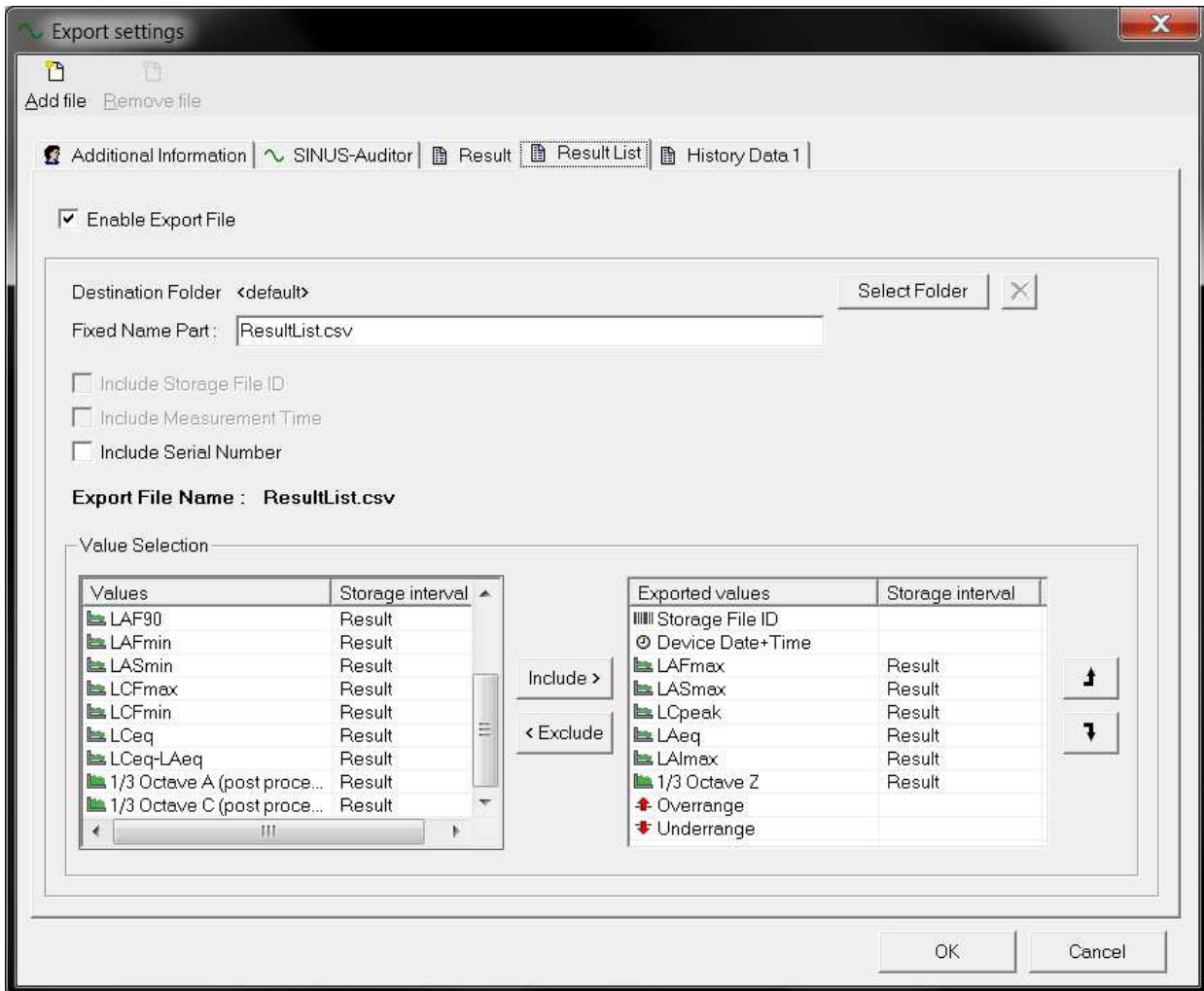

Figure 2.11: Export - Result List

Result tab

This tab provides the export only of end results as txt or csv. Just type the filename with the desired format.

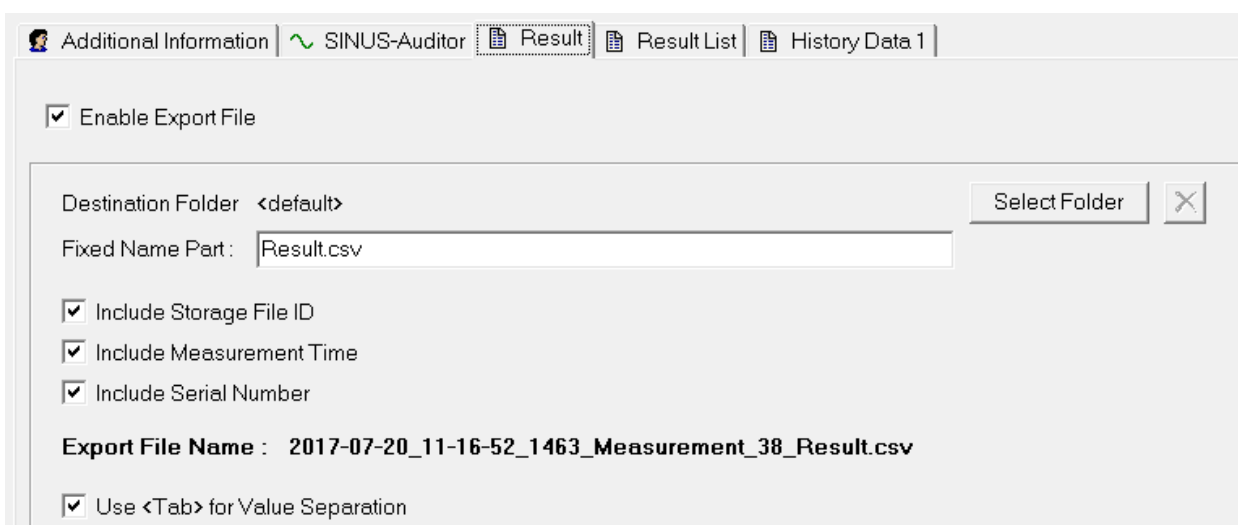

Figure 2.12: Export - Result

Auditor tab

This tab provides the export of full data as Auditor readable smr format.

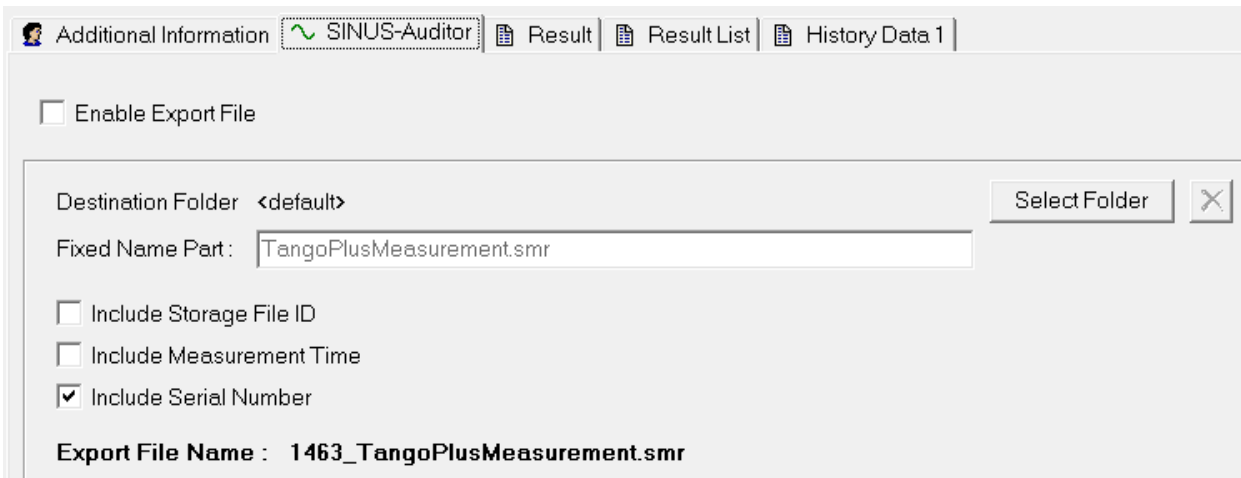

Figure 2.13: Export - Auditor

Additional Information tab

This tab allows to put additional information showing up in all export files. Especially a measurement time can be applied manually using the **Set Time** button.

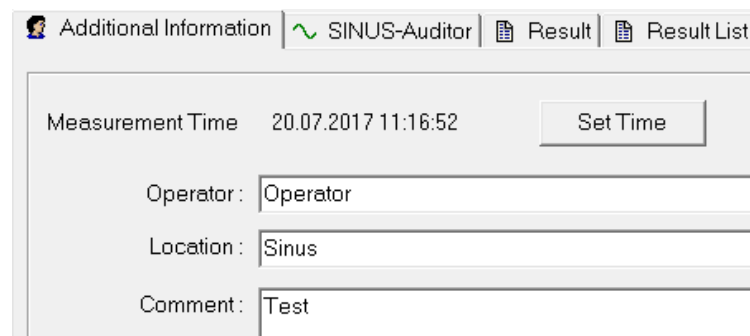

Figure 2.14: Export - Additional Information

2.4 Calibrate

A list of the approved calibrators and the accuracy classes achieved is given in section 4.2. Follow the instructions below to calibrate the device at 1 kHz.

2.4.1 Calibrate using Tango-Utilities

1. Connect Tango_Plus to the PC.
2. Start **Tango-Utilities**.
3. Insert the microphone into the calibrator and activate the calibration signal. The reference calibration level is 94 dB for this method.
4. Press the **CAL** button in **Tango-Utilities**. "Calibration activated" appears in the status bar. To cancel the calibration procedure, press the stop button.

- Having finished you are asked to adopt the new calibration values. If something went wrong, an error message appears.

2.4.2 Calibrate Tango_Plus directly

- Switch on the device.
- Press the Setup-Button and navigate to the calibration menu.
- Adjust the calibration level and execute "Start Calibration". The reference calibration level will be blinking on the display (e.g. 94 dB). You may adjust this value with the Scroll-Button (94 dB, 104 dB or 114 dB).
- Switch on the calibrator (select the correspondig level on the calibrator, if necessary) and insert the microphone into the calibrator.
- Press the OK-Button and Calibration starts. First, the noise level of the device is measured and second the calibrator signal. During calibration, **CAL** is blinking on the display. When **CAL** stops blinking, the calibration is finished. The measured level is displayed enabling you to check the calibration result.
- Press the OK-Button to save the new sensitivity value or press the Setup-Button to reject.
- You have left the calibration menu and the device is in STOP-Mode.

If the calibration has been affirmed the symbol **CAL** is shown on the display until the next start of Tango_Plus.

NOTICE!

If the new value deviates more than 3 dB from the last one, it is not accepted. The message "Error" is displayed in this case. This tolerance is reduced to ± 1.5 dB for approvable devices.

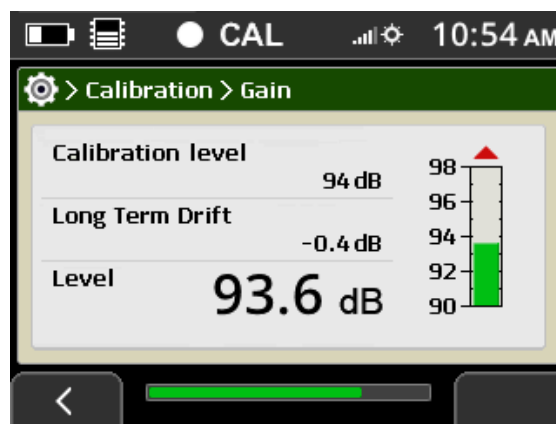

Figure 2.15: Calibration menu

NOTICE!

On the device you can reset the calibration result to factory value via: "Menu > Calibration > Reset Calibration".

2.5 Measure

For legally binding measurements the device must run on batteries/rechargeables. Therefore the device has to be controlled with the keypad (section 1.4.1). Follow the instructions below to perform a binding measurement:

1. Position the device (held in the hand or mounted upon a tripod).
2. Switch on the device.
3. Check the battery charge status.
4. Use the Record-Button to enable/disable data recording.
5. Press the Start-Button to start the measurement.
6. Press the Stop-Button to stop the measurement.

2.5.1 Measure low sound levels

You do not have to make special preparations for measuring low level sounds.

2.5.2 Overload and Underrange

The indicator for overload and underrange is located on the right or left respectively of the bar graph on the display. They are displayed, when the linearity range is left.

NOTICE! A reset of the overload or underrange display is only possible by stopping and restarting the measurement.

The representation on the display is explained in the following table 2.4.

Tango-Utilities	Display	Description
Overflow		No overload has occurred in current measurement.
Overflow	△	Overload has occurred in current measurement.
Overflow	▲	Currently an overload occurs.
Underrange		No underrange has occurred in current measurement.
Underrange	▽	Underrange has occurred in current measurement.
Underrange	▼	Currently an underrange occurs.

Table 2.4: Display of overload and underrange

2.5.3 Calibrated Measurement

The calibration control procedure ensures that it is clear for the measurements taken, whether the instrument is in the calibrated state or not. For Tango_Plus a measurement is considered as calibrated, if the device has been successfully calibrated between switch on (deletes the calibration status) and the start of the measurement. The following information is collected:

- Date and time of calibration
- Sensitivity
- Deviation from previous calibration (checked during calibration but not saved)

- Deviation from original factory calibration (checked during calibration but not saved)

Loss of calibration status is effected by:

- Switching off the device (except when the measurement start is scheduled with a preset start time)
- Switch off the device during measurement breaks in repeat mode
- Cancel of calibration

2.5.4 View measurement results on Tango_Plus

It is possible to view the measurement results on the device via: “Menu > Stored Files > [File] > View Results”. There you find resulting level and resulting 1/3 octaves as well as information about calibration status, microphone sensitivity and whether the microphone was directly connected or detached.

2.5.5 Print results

If a printer is connected, you may set results to be printed after the measurement (section 2.2.1) under: Functions > Measurement Values > [Value] > Print Result. This is possible for all sound levels that result in one number like for example L_{Aeq} or L_{CFmax} . You are asked to print after each measurement automatically. You may also recall a measurement and print the result via: Functions > Print Results.

3 Information for type approval

Tango_Plus can be used in different configurations, first as a classic handheld level meter with direct incidence and second as part of the Outdoor Kit with sound incidence from the sides. All configurations are designed according to IEC 61672-1:2014, accuracy class 1 and immunity to interference group Z and according to IEC 61260:2003 for 1/1 and 1/3 octaves. Additionally there is a configuration under electric test for type approval.

NOTICE! The configuration is set on the device under:
Menu > Device > Options > Microphone Connection.

Using Tango_Plus the following sound level values may be measured: L_{AF} , L_{AFmax} , L_{AFmin} , L_{CF} , L_{CFmax} , L_{CFmin} , L_{Almax} , L_{AS} , L_{ASmax} , L_{ASmin} , L_{Cpeak} , L_{Aeq} , L_{Ceq} , $L_{Ceq-L_{Aeq}}$, L_{AE} , L_{AFT} , L_{AFTeq} , $L_{AFTeq-L_{Aeq}}$, L_{Aeq} , $L_{Aeq-L_{Aeq}}$, $L_{Cpeak>7s}$ and L_{AF7s} . A detailed description of these values is given in table 1.1 in section 1.6.

In addition, linear averaged 1/3 octaves and full octaves can be measured with frequency weightings A, C and Z.

NOTICE! The number of the firmware version can be displayed (section 2.2.1).

3.1 Configuration as classical handheld level meter

As classical handheld level meter Tango_Plus is used with attached or detached microphone (via Micro-extension cable) and windscreen W2. Under "Settings > Device > Options > Microphone Connection" select "Direct Connection" or "Cable Connection" accordingly. For both configurations the frequency response is nearly equal and within the tolerance. The direction of sound incidence is 0° referring to the microphone axis. The following parts are permitted for the use of Tango_Plus under mandatory verification according to type approval :

- Tango_Plus (907004.2)
- Micro extension cable 3m (907308)
- Calibrator Cal200 1/2" type1 PCB (800934.4)
- Calibrator Type 4231 (B&K) (800043.2)
- Windscreen W2 (800253.0)

The *Windscreen W2* is black coloured and spherically with a diameter of 69 mm.

3.1.1 Frequency response of Tango_Plus - Configuration SLM

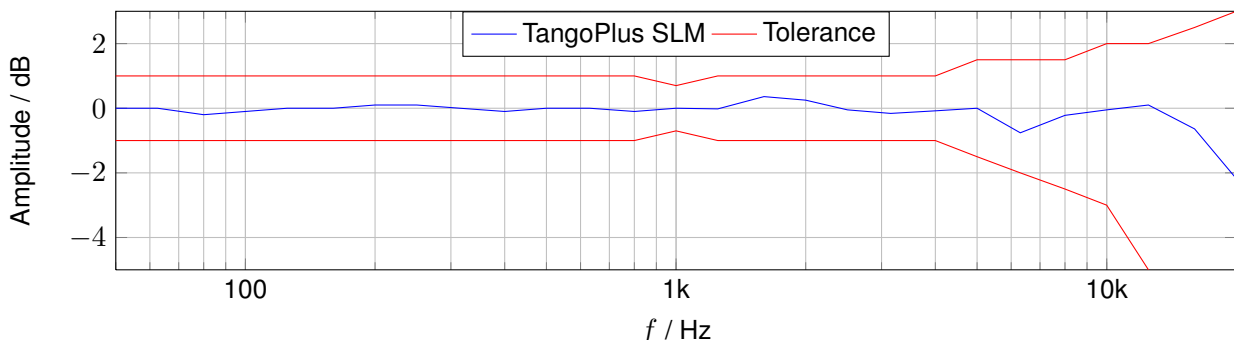

mid frequency in Hz	cut-off frequency in Hz	Correction value in dB
50	44,7	0,00
63	56,2	0,00
80	70,8	0,00
100	89,1	0,00
125	112	0,00
160	141	0,00
200	178	0,00
250	224	0,00
315	282	0,00
400	355	0,00
500	447	0,00
630	562	0,00
800	708	0,00
1000	891	0,00

mid frequency in Hz	cut-off frequency in Hz	Correction value in dB
1250	1122	-0,05
1600	1413	-0,10
2000	1778	-0,20
2500	2239	-0,20
3150	2818	0,40
4000	3548	0,10
5000	4467	0,60
6300	5623	0,80
8000	7079	0,90
10000	8913	0,95
12500	11220	1,00
16000	14130	1,40
20000	17780	2,00
-	-	-

Table 3.1: Correction to the frequency raw data for the Configuration SLM.

3.1.2 Directional characteristics - Configuration SLM

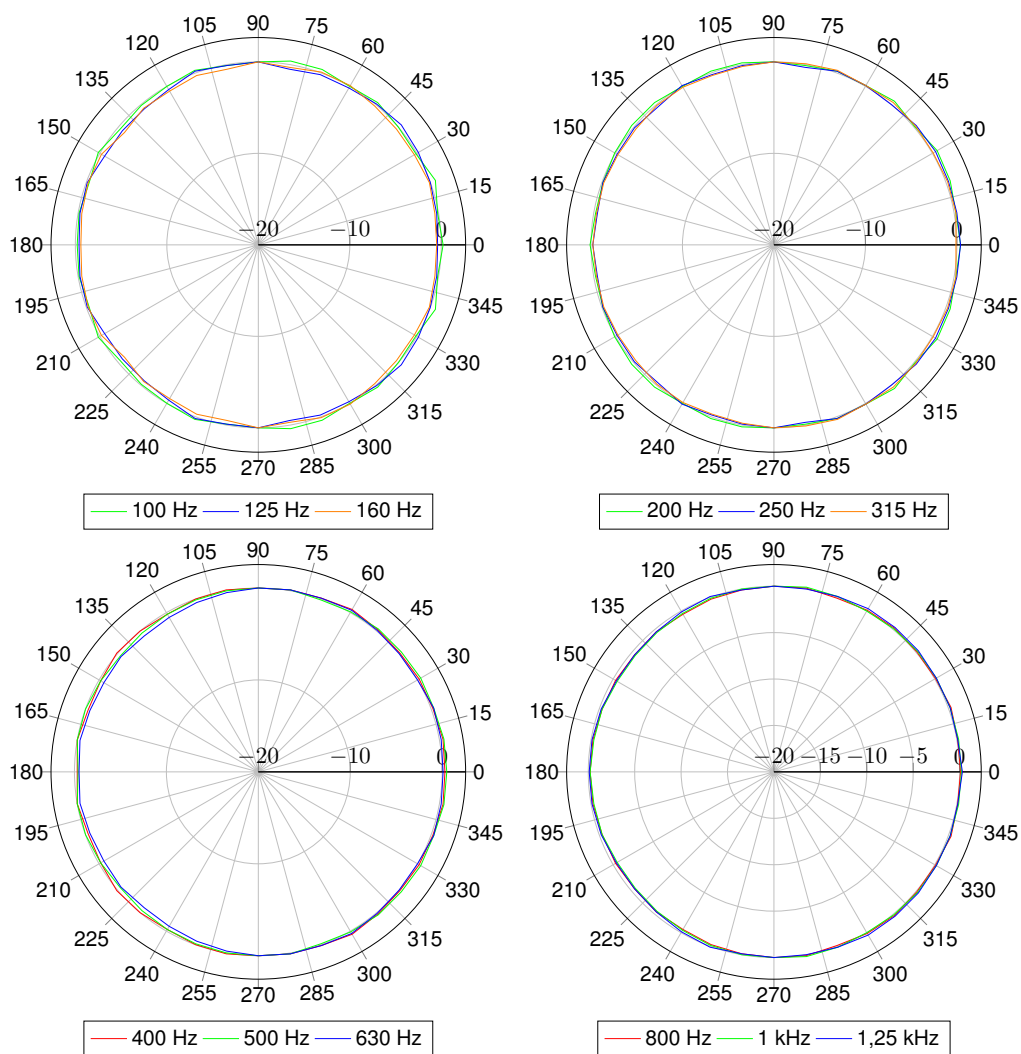

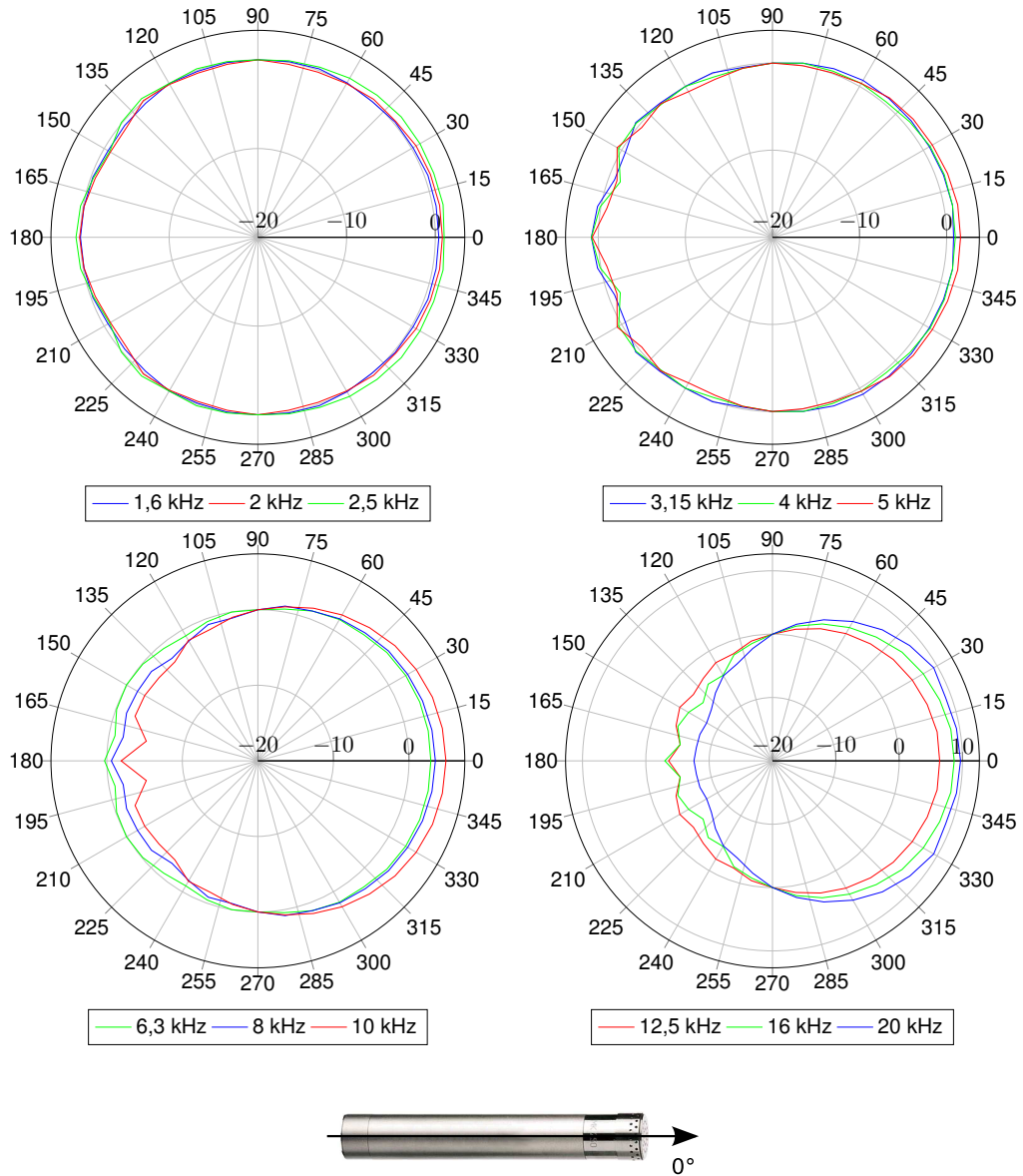

Figure 3.1: Mikrophone axis

3.1.3 Corrections according to case reflections - Configuration SLM with connected microphone

The corrections are valid for the whole Tango_Plus station, so including windscreen W2, with attached microphone. With detached microphone there is no effect.

NOTICE! Corrected values are calculated by adding the corrections to the measured pure values.

mid frequency in Hz	cut-off frequency in Hz	Case refl. corr. in dB
63	56,2	0,1
80	70,8	-0,38
100	89,1	-0,3
125	112	-0,2
160	141	-0,24
200	178	-0,19
250	224	-0,02
315	282	-0,14
400	355	-0,03
500	477	-0,04
630	562	-0,12
800	708	0,01
1000	891	-0,15

Table 3.2: Case reflection corrections in 1/3 octaves
(manufacturer's specification: measurement uncertainty at 95% certainty ± 0 dB)

mid frequency in Hz	cut-off frequency in Hz	Case refl. corr. in dB
1030	1.000,0	-0,31
1090	1.059,3	0,03
1150	1.122,0	0,04
1220	1.188,5	-0,06
1300	1.258,9	0,09
1370	1.333,5	-0,01
1450	1.412,5	0,24
1540	1.496,2	0,08
1630	1.584,9	-0,38
1730	1.678,8	-0,13
1830	1.778,3	0,22
1940	1.883,6	0,14
2050	1.995,3	0,3
2180	2.113,5	-0,09
2300	2.238,7	-0,37
2440	2.371,4	-0,05
2590	2.511,9	-0,14
2740	2.660,7	-0,23
2900	2.818,4	-0,41
3070	2.985,4	0
3250	3.162,3	0,44
3450	3.349,7	0,11
3650	3.548,1	0,56
3870	3.758,4	0,33
4100	3.981,1	-0,82

mid frequency in Hz	cut-off frequency in Hz	Case refl. corr. in dB
4340	4.217,0	-0,29
4600	4.466,8	-0,51
4870	4.731,5	0,21
5200	5.011,9	0,47
5500	5.308,8	-0,01
5800	5.623,4	-0,2
6100	5.956,6	-0,31
6500	6.309,6	0,24
6900	6.683,4	0,24
7300	7.079,5	-0,29
7700	7.498,9	-0,06
8200	7.943,3	0,28
8700	8.414,0	-0,03
9200	8.912,5	-0,17
9700	9.440,6	0,12
10300	10.000,0	-0,12
10900	10.592,5	-0,16
11500	11.220,2	-0,02
12200	11.885,0	-0,07
13000	12.589,3	0,05
13700	13.335,2	-0,05
14500	14.125,4	0
15400	14.962,4	-0,18
16300	15.848,9	0,04
-	-	-

Table 3.3: Case reflection corrections in 1/12 octaves
(manufacturer's specification: measurement uncertainty at 95% certainty ± 0 dB)

3.2 Configuration with weather protection - Outdoor Kit

With the optional Outdoor Kit Tango_Plus can be used as temporary monitoring station for environmental noise. Under "Settings > Device > Options > Microphone Connection" "Weather Protector" must be selected. The runtime from the external battery depends on the measurement configuration, a typical value is 2 month. The data are stored locally. The direction of sound incidence is 90° referring to the microphone axis.



Figure 3.2: Tango "Outdoor Kit"

The following items are included in the outdoor kit (figure 3.2):

- Peli Case 1500 with foam insert and LEMO7 Cable intern (907305.3)
- V-Mount Li-Akku 14.8V/6.1A (801232.3)
- FD-BT16V Li-Ion Charger (801352.5)
- Tango DC/DC-Adapter (907240.X)
- Microphone cable Tango_Plus, 3m (907308)
- Microphone cable Tango_Plus, 0.4m (907309)
- TA202L dry adapter Tango (801419.8)
- Weather Protector SWS1 (907315.8)
- Tripod (800630.0)

3.2.1 Weather Protector SWS1

First disconnect the microphone from Tango_Plus and carefully unscrew the **Microphone Capsule (A)** from the **Microphone Preamplifier (B)** (figure 3.3). Be careful not to release the protective grille from the capsule, but to unscrew the entire capsule unit.

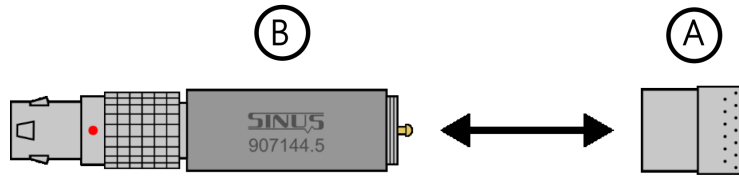

Figure 3.3: Pre-amplifier and capsule

Next, insert the **TA 202L (C)** dry adapter between the components that are currently separated (figure 3.4). Check whether the black sealing ring of the dry adapter is still correctly located on the thread root.

NOTICE! Without the dry adapter Tango_Plus must not be operated with the weather protection!

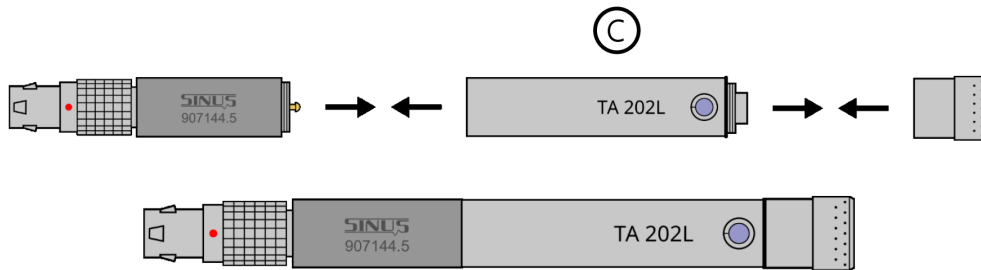

Figure 3.4: TA202L mounting between pre-amplifier and capsule

Next, prepare the weather protection for the assembly. First remove the **Windscreen (D)** (figure 3.5).

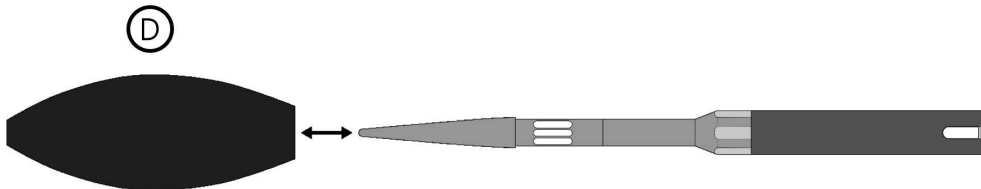

Figure 3.5: Weather protector and windscreen

Then unscrew the **Protective Sleeve (E)** from the **Shaft (G)** and loosen the **Shank Head (F)** slightly. Be sure to use strength only on the stainless steel components and not damage the fee. Then turn off the **socket (H)** (figure 3.6).

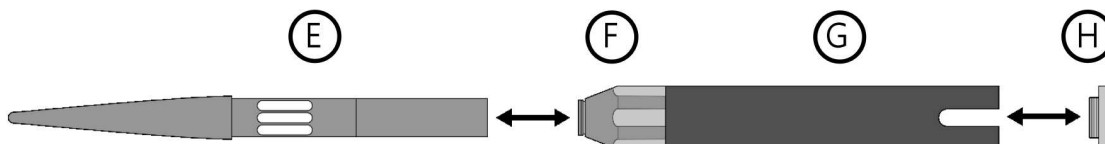

Figure 3.6: Disassembling of the Weather protector SWS1

Pass the **Tango_Plus microphone cable (I)** through the shaft, so that the socket end can be connected to the composite microphone unit on the pre-amplifier. At the end of the shaft, guide the cable through the recess before screwing the **socket (H)** back in (figure 3.7).

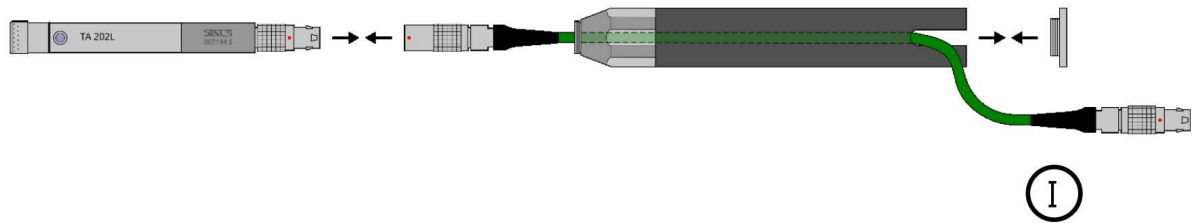

Figure 3.7: Mounting the cable

Then carefully slide the microphone unit into the **protective sleeve (E)** until the head of the microphone capsule is at the end of the sleeve. Now you can screw the sleeve back onto the **shaft (G)**. Keep the weather protection at a slight angle, so that the head surface of the microphone remains at the end of the sleeve and does not slip. Tighten the previously loosened **shaft head (F)** to fix the microphone. The weather protection can now be set up vertically without the microphone lowering. Finally the **Windscreen (D)** can be put on again. Make sure that the lower end of the windscreen is flush with the **shaft head (F)** (figure 3.8).

NOTICE! The correct positions of microphone and windscreen must always be guaranteed. Otherwise there will be falsifications of the later measurements.

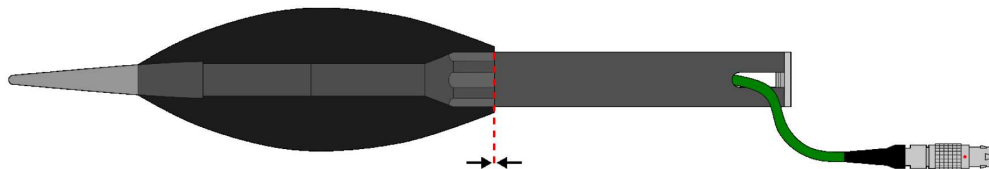

Figure 3.8: Mounting the windscreen

NOTICE! For later calibrations, it is sufficient to remove the windscreen (D) and the protective sleeve (E). Make sure that the microphone is in the correct position vertically.

The transparent picture of the final composition (figure 3.9) shows, that the microphone is closed to the weather protection inside.

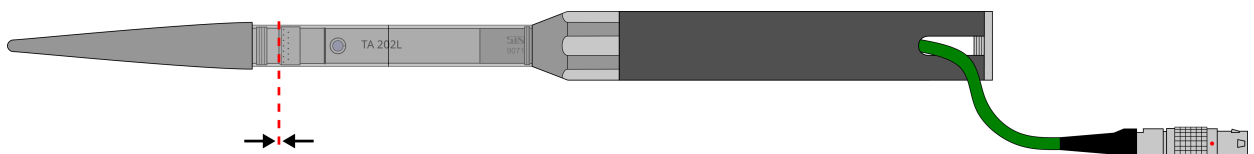
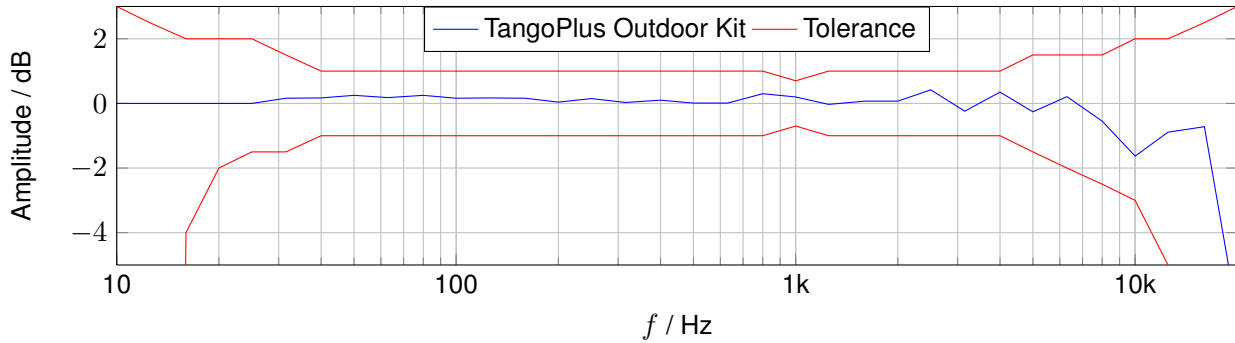

Figure 3.9: Transparent picture of the inner composition

3.2.2 Frequency response of the microphone - Configuration Outdoor Kit



If the configuration with weather protector is selected in the device, the following values are added internally to result in the frequency response shown above.

mid frequency in Hz	cut-off frequency in Hz	Correction value in dB
50	44,7	0,00
63	56,2	0,00
80	70,8	0,00
100	89,1	0,00
125	112	0,00
160	141	0,00
200	178	0,00
250	224	0,00
315	282	0,00
400	355	0,00
500	447	0,00
630	562	0,00
800	708	0,00
1000	891	0,00

mid frequency in Hz	cut-off frequency in Hz	Correction value in dB
1250	1122	0,30
1600	1413	0,30
2000	1778	0,30
2500	2239	0,4
3150	2818	0,9
4000	3548	1,0
5000	4467	2,2
6300	5623	3,5
8000	7079	4,0
10000	8913	4,0
12500	11220	4,0
16000	14130	4,0
20000	17780	4,0
-	-	-

Table 3.4: Correction to the frequency raw data for the Configuration Outdoor Kit.

3.2.3 Directional characteristics - Configuration Outdoor Kit

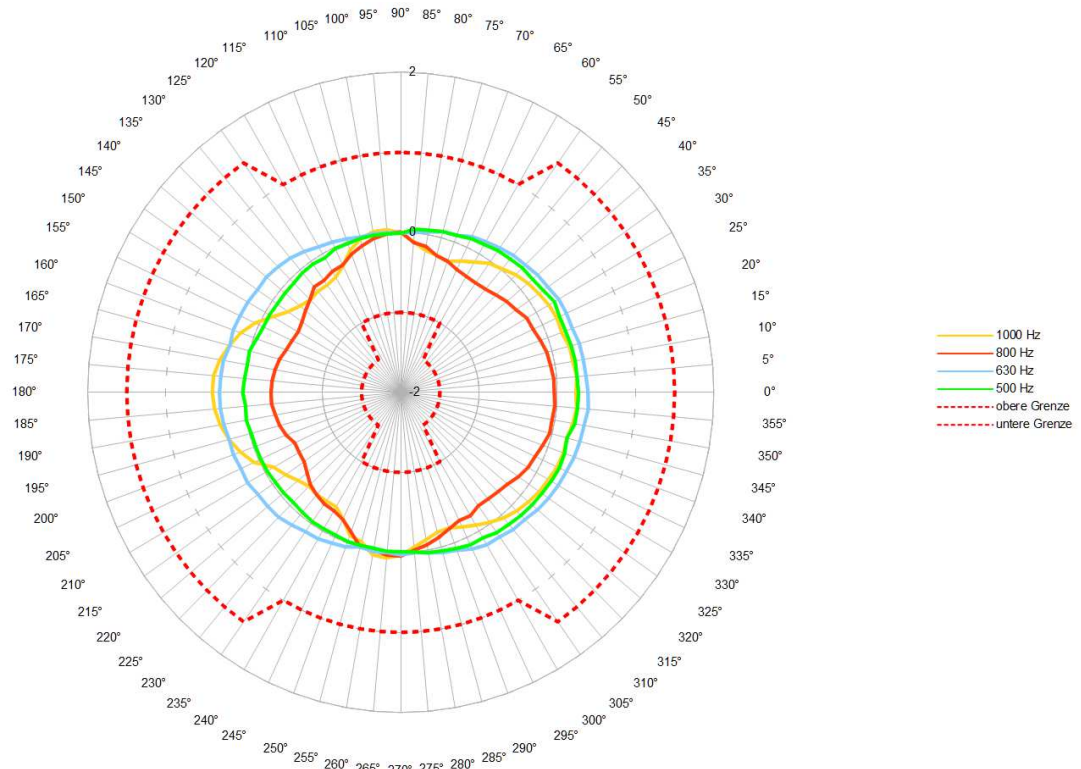
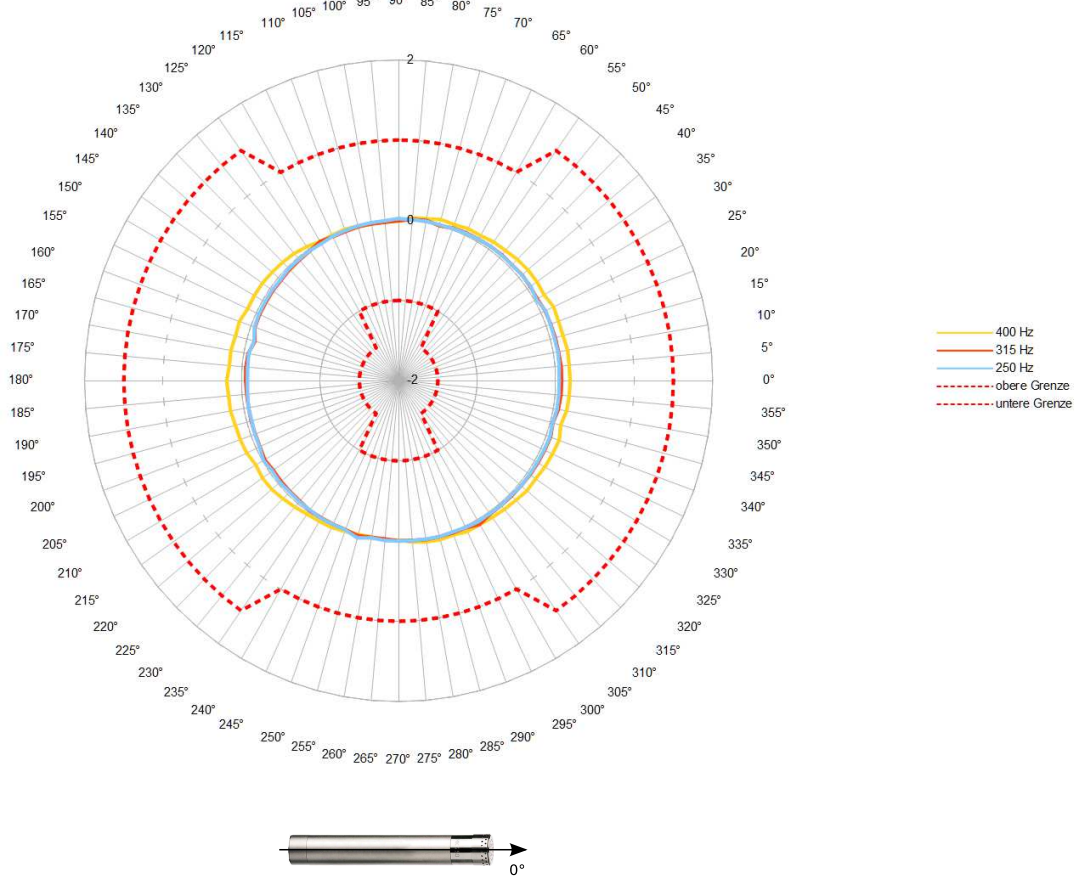

3 INFORMATION FOR TYPE APPROVAL

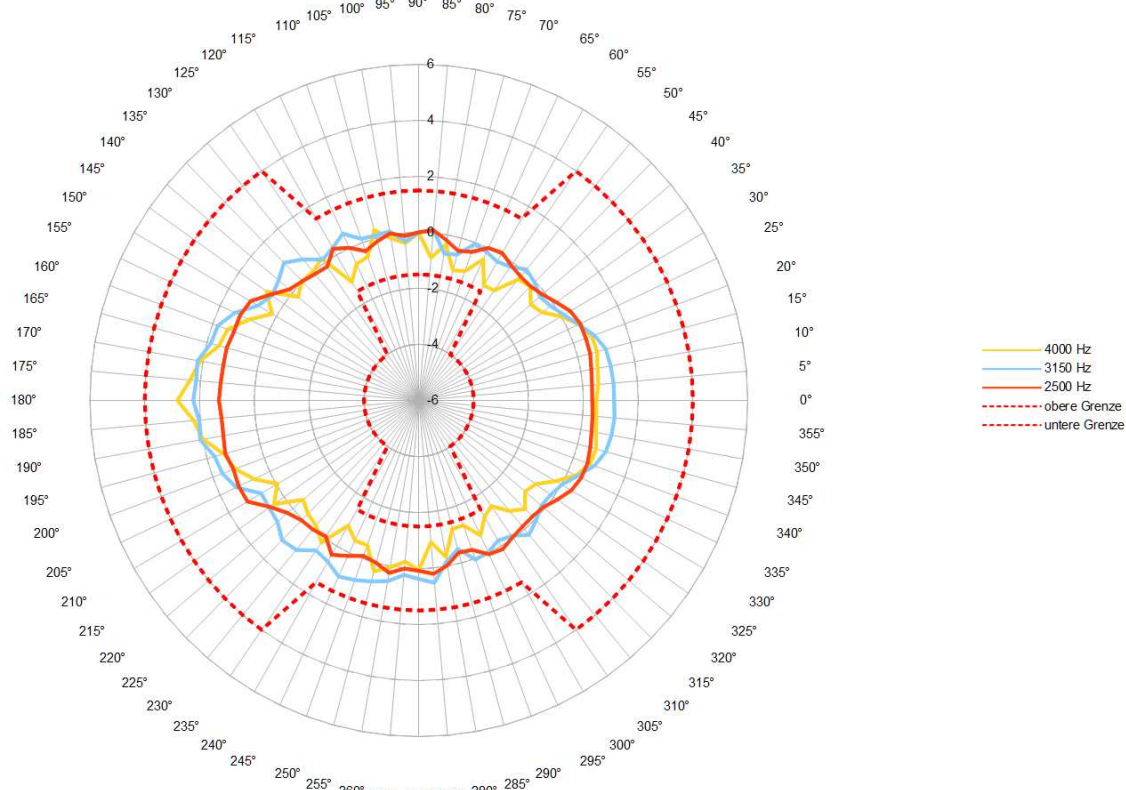
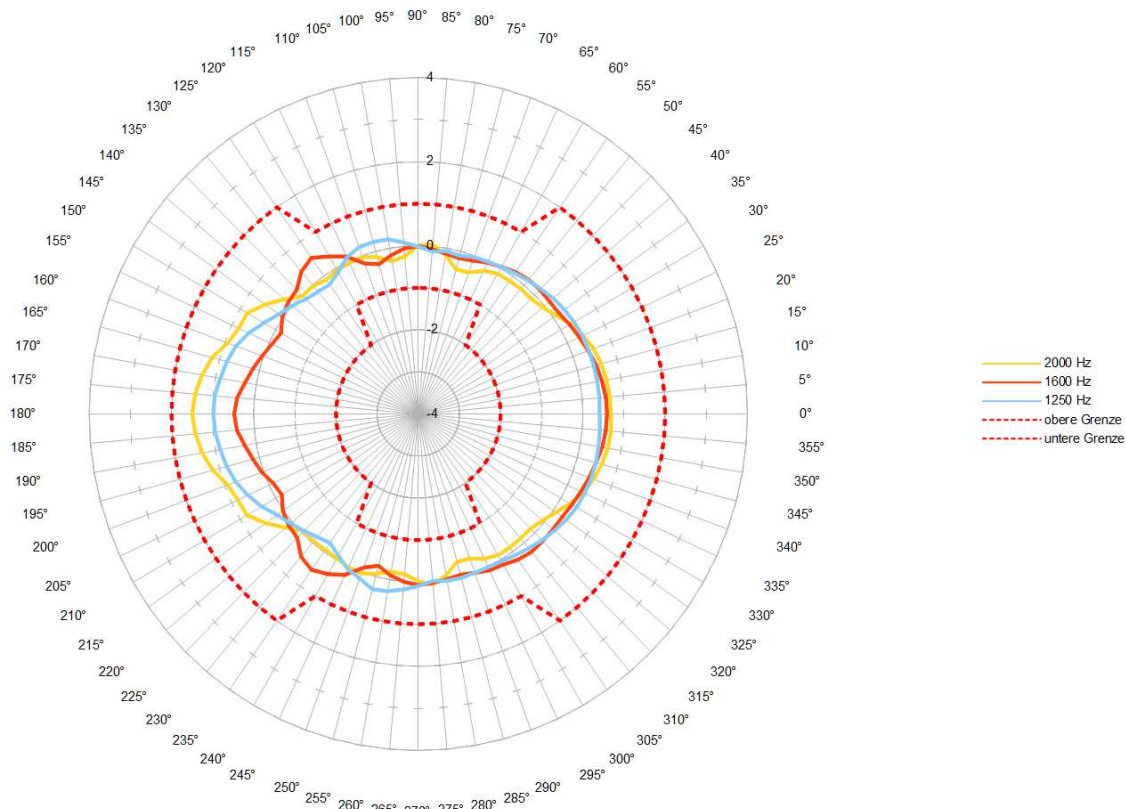

3.2 Configuration with weather protection - Outdoor Kit

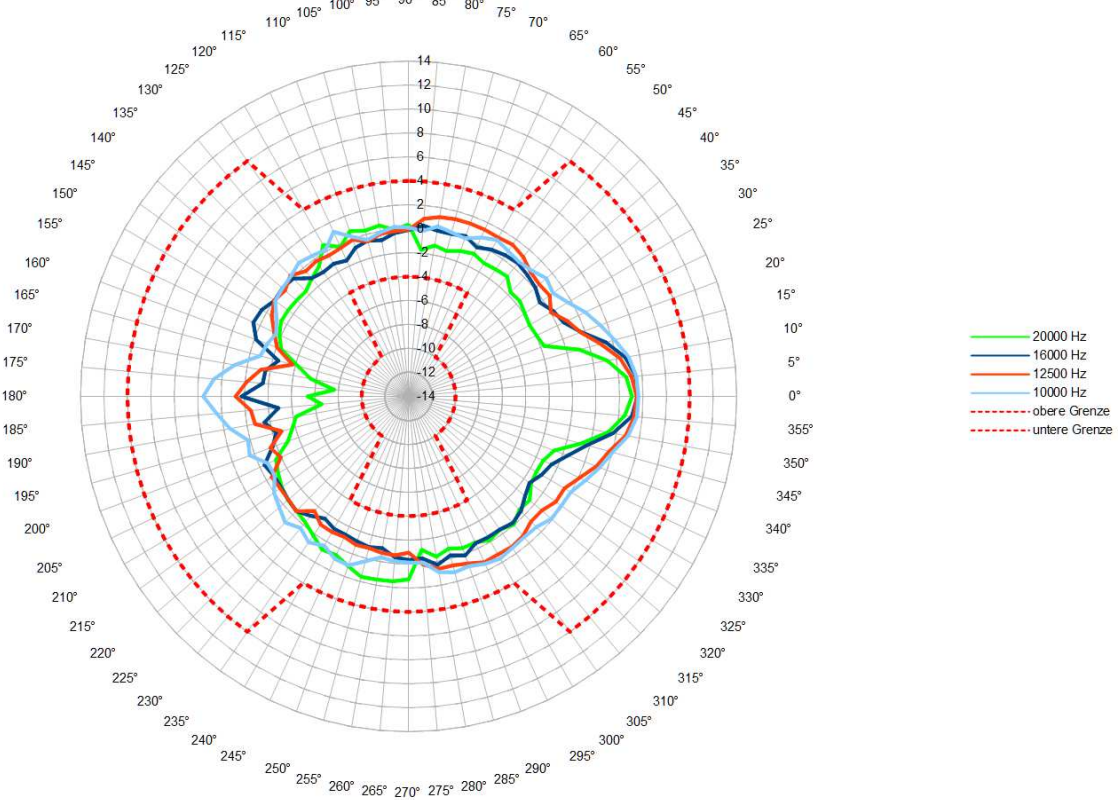
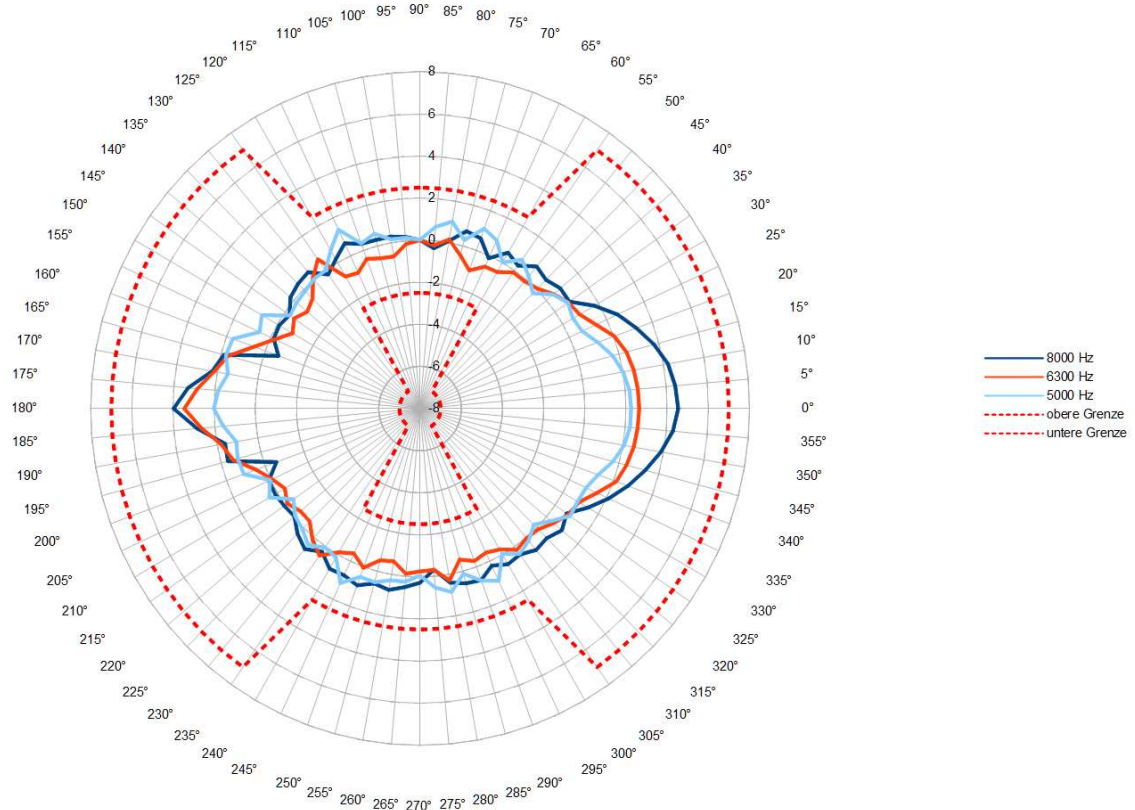

3.2.4 Corrections for the use of the weather protector

The corrections are valid for the whole Tango_Plus station, so including weather protection SWS1. Corrected values are calculated by adding the corrections to the measured pure values.

mid frequency in Hz	cut-off frequency in Hz	Case refl. corr. in dB
63	56,2	-0,43
80	70,8	-0,13
100	89,1	0,26
125	112	-0,1
160	141	-0,1
200	178	0,04
250	224	0,01

mid frequency in Hz	cut-off frequency in Hz	Case refl. corr. in dB
315	282	0,15
400	355	0,13
500	447	0,1
630	562	0,3
800	708	0,02
1000	891	0,19
-	-	-

Table 3.5: Case reflection corrections in 1/3 octaves
(manufacturer's specification: measurement uncertainty at 95% certainty ± 0 dB)

mid frequency in Hz	cut-off frequency in Hz	Case refl. corr. in dB
1030	1.000,0	-0,02
1090	1.059,3	0,34
1150	1.122,0	0,26
1220	1.188,5	0,14
1300	1.258,9	-0,06
1370	1.333,5	0,29
1450	1.412,5	0,21
1540	1.496,2	0,13
1630	1.584,9	0,23
1730	1.678,8	0,1
1830	1.778,3	-0,01
1940	1.883,6	0,33
2050	1.995,3	0,12
2180	2.113,5	0,06
2300	2.238,7	-0,09
2440	2.371,4	-0,19
2590	2.511,9	-0,05
2740	2.660,7	0,19
2900	2.818,4	0,04
3070	2.985,4	-0,08
3250	3.162,3	-0,54
3450	3.349,7	-0,5
3650	3.548,1	0,18
3870	3.758,4	0,54
4100	3.981,1	0,12

mid frequency in Hz	cut-off frequency in Hz	Case refl. corr. in dB
4340	4.217,0	-0,67
4600	4.466,8	-0,49
4870	4.731,5	0
5200	5.011,9	-0,79
5500	5.308,8	-1,45
5800	5.623,4	-0,56
6100	5.956,6	-0,31
6500	6.309,6	-0,98
6900	6.683,4	0,06
7300	7.079,5	-0,69
7700	7.498,9	-0,65
8200	7.943,3	-0,84
8700	8.414,0	-0,77
9200	8.912,5	-0,52
9700	9.440,6	0,59
10300	10.000,0	0,63
10900	10.592,5	-0,01
11500	11.220,2	-0,03
12200	11.885,0	1,16
13000	12.589,3	2,11
13700	13.335,2	1,98
14500	14.125,4	1,4
15400	14.962,4	1,92
16300	15.848,9	1,32
-	-	-

Table 3.6: Case reflection corrections in 1/12 octaves
(manufacturer's specification: measurement uncertainty at 95% certainty ± 0 dB)

3.3 Configuration for electrical test

For electrical testing use the equivalent electrical impedance device K65 (figure 3.10) only. Table 3.7 describes its properties.



Figure 3.10: Image of K65

Feature	Value
Model Transducer type	Equivalent electrical impedance for 1/2" Mikrophone preamplifier
Capacitance CE	22 pF
Temperature range	+20 ... +60 °C
Diameter	17 mm
Length	60 mm
Weight	46 g

Table 3.7: Technical data of K65 (800030.3)

This configuration is dedicated to type approval test only. "Direct connection" must be selected under "Functions > Device > Options > Microphone Connection".

3.3.1 Frequency response of the microphone - Configuration for electrical test

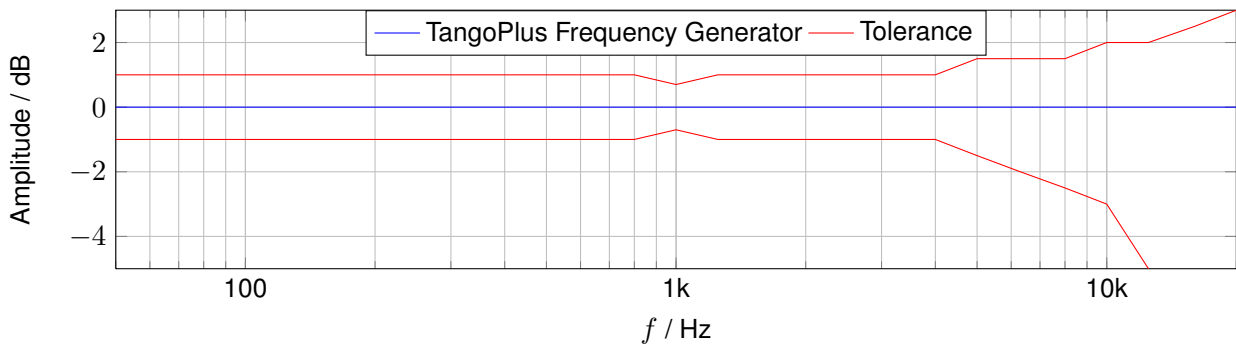

mid frequency in Hz	cut-off frequency in Hz	Correction value in dB
50	44,7	0,00
63	56,2	0,00
80	70,8	0,00
100	89,1	0,00
125	112	0,00
160	141	0,00
200	178	0,00
250	224	0,00
315	282	0,00
400	355	0,00
500	447	0,00
630	562	0,00
800	708	0,00
1000	891	0,00

mid frequency in Hz	cut-off frequency in Hz	Correction value in dB
1250	1122	0,00
1600	1413	0,00
2000	1778	0,00
2500	2239	0,00
3150	2818	0,00
4000	3548	0,00
5000	4467	0,00
6300	5623	0,00
8000	7079	0,00
10000	8913	0,00
12500	11220	0,00
16000	14130	0,00
20000	17780	0,00
-	-	-

Table 3.8: Correction to the frequency raw data for the Configuration Electrical test.

3.3.2 Details on EMC

When the device is exposed to electromagnetic emissions the lower limits of the ranges in table 3.11 are increased by 5 dB. Within these changed ranges the error limits according to IEC 61672-1:2014 are maintained. The level linearity range changes to 40. . . 107 dB(A) when the device is exposed to electromagnetic emissions. There will be no performance loss in the device after electrostatic discharges (touch discharge up to 4 kV and air discharge up to 8 kV).

ATTENTION! Legally binding measurements *must not* be performed, if the device is connected to public power supply.

3.3.3 EMC test

The measurement is performed for the following configurations:

Low interference immunity: USB cable linked to public power supply and microphone extension cable connected

Maximim interference immunity: USB cable and microphone extension cable disconnected

3.3.4 Mains frequency and high-frequency fields

Tango_Plus complies with IEC 61672-1:2014 with respect to interference immunity to mains frequency and high-frequency fields. The interference immunity to mains frequency and high-frequency fields is highest when the device is running on batteries/rechargeables without USB cable connected.

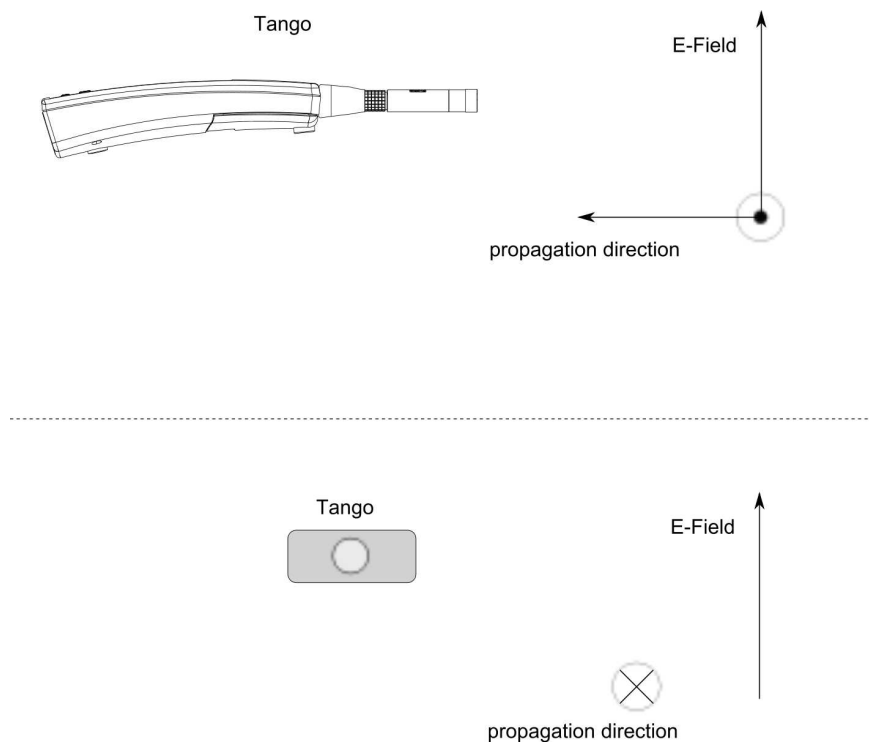

Figure 3.11: Alignment measurement HF immunity

If Tango_Plus is connected to a PC and measuring high-frequency emissions are highest. Additionally, the interference immunity to mains frequency and high-frequency fields is lowest in this configuration (alignment see fig. 3.11). The next lowest emission level is reached in the same configuration, but in STOP-Mode.

In compliance with paragraph 6.6.9 of IEC 61672-1:2014 Tango_Plus is *not* appropriate to measure levels lower than 74 dB for an electric field strength exceeding 10 V/m.

3.4 Effect of environmental conditions

In order to avoid the effect of sound reflections from the body of the operator interfering with the measurement, Tango_Plus should be located as far as possible from the body. Thus, when actually performing the measurement, the operator should place himself at a distance behind the tripod-mounted meter, or extend the hand-held meter as far from the body as is comfortable.

NOTICE! When the temperature changes by more than 15 °C an acclimatization time of 30 min must be safeguarded.

Within the limits of the linear operating ranges, the measurement of low sound levels is possible without restrictions. Then a sufficient signal-to-noise ratio is guaranteed.

NOTICE! If there is a significant change in the static air pressure, an acclimatization time of 1 min must be observed to ensure pressure equalization through the holes provided.

3.4.1 Effect of mechanical vibration

To measure the influence of mechanical vibrations you need a second sound level meter with officially verified calibration as reference device. The microphone of the reference device has to be positioned in a maximum distance of 0.2 m from the microphone of the tested device and must not be exposed to the mechanical vibrations of the exciter.

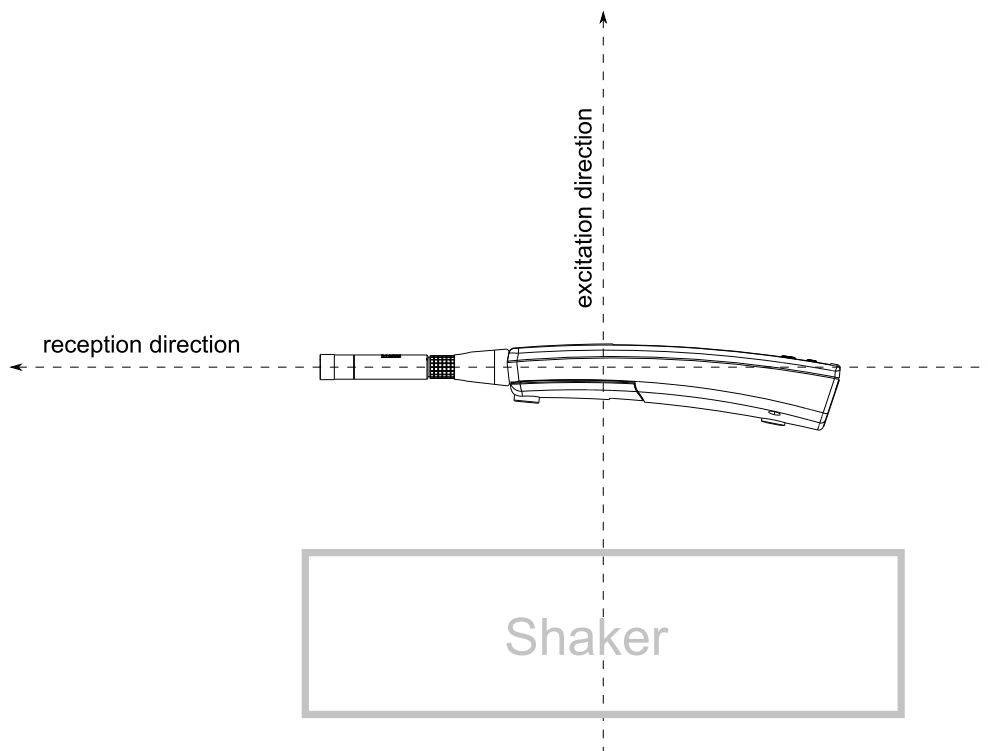

Figure 3.12: Alignment for vibration test

If the device is exposed to mechanical vibration with an acceleration of 1 m/s^2 perpendicular to the membrane plane of the microphone, the lower limit of the linear operating range increases to 75 dB for the frequencies 31,5 Hz, 63 Hz, 125 Hz, 250 Hz, 500 Hz, 630 Hz, 800 Hz and 1000 Hz, frequency weighting A.

If the device is exposed to mechanical vibration with an acceleration of 1 m/s^2 parallel to the membrane plane of the microphone, the lower limit of the linear operating range increases to 58 dB for the frequencies 31,5 Hz, 63 Hz, 125 Hz, 250 Hz, 500 Hz, 630 Hz, 800 Hz and 1000 Hz, frequency weighting A.

3.5 Self-generated noise

In a sound field with an insignificant contribution to the inherent noise, levels of $L_{AF} < 14 \text{ dB}$ as well as $L_{CF} < 16 \text{ dB}$ are to be expected.

The electrical noise inherent in the preamplifier (terminated with spare capacity and 50Ω at the input) will produce $L_{AFmax} < 14 \text{ dB}$ as well as $L_{CFmax} < 20 \text{ dB}$ in the display device.

3.6 Linear operating ranges

The operating ranges given below are only valid for calibrated devices! The starting value for each level linearity test is 94 dB at 1 kHz.

Frequency	max in dB(A)	min in dB(A)	Range in dB(A)
31,5 Hz	100	25	75
1 kHz	140	25	115
4 kHz	140	27	113
8 kHz	139	27	112
12,5 kHz	135	27	108

Table 3.9: Linear operating ranges A-weighted

Frequency	max in dB(C)	min in dB(C)	Range in dB(C)
31,5 Hz	137	62	75
1 kHz	140	30	110
4 kHz	138	30	108
8 kHz	137	30	107
12,5 kHz	133	30	103

Table 3.10: Linear operating ranges C-weighted

3.6.1 Level linearity range

The following table 3.11 contains the measurement ranges for A-weighted sound levels and the C-weighted peak sound level for microphone sensitivity of 50 mV/Pa.

Fast/Slow/Leq in dB(A)	L_{AE} in dB(A)	L_{Cpeak} in dB(C)
25... 140	ab 25	37... 143

Table 3.11: Level linearity ranges for A-weighted sound levels and C peak

3.7 Frequency weighting

<i>f</i>	A Tango	C Tango	A Standard	C Standard	Diff A	Diff C
10	-67,93	-13,76	-70,00	-14,30	2,07	0,54
12,5	-62,56	-10,84	-63,40	-11,20	0,84	0,36
16	-55,90	-8,12	-56,70	-8,50	0,80	0,38
20	-50,00	-5,94	-50,50	-6,20	0,50	0,26
25	-44,54	-4,20	-44,70	-4,40	0,16	0,20
31,5	-39,36	-2,90	-39,40	-3,00	0,04	0,10
40	-34,36	-1,88	-34,60	-2,00	0,24	0,12
50	-30,14	-1,22	-30,20	-1,30	0,06	0,08
63	-26,12	-0,78	-26,20	-0,80	0,08	0,02
80	-22,32	-0,46	-22,50	-0,50	0,18	0,04
100	-19,06	-0,28	-19,10	-0,30	0,04	0,02
125	-16,12	-0,18	-16,10	-0,20	-0,02	0,02
160	-13,22	-0,10	-13,40	-0,10	0,18	0,00
200	-10,82	-0,06	-10,90	0,00	0,08	-0,06
250	-8,66	-0,04	-8,60	0,00	-0,06	-0,04
315	-6,62	0,00	-6,60	0,00	-0,02	0,00
400	-4,74	0,00	-4,80	0,00	0,06	0,00

<i>f</i>	A Tango	C Tango	A Standard	C Standard	Diff A	Diff C
500	-3,22	0,00	-3,20	0,00	-0,02	0,00
630	-1,92	0,00	-1,90	0,00	-0,02	0,00
800	-0,78	0,00	-0,80	0,00	0,02	0,00
1000	0,00	0,00	0,00	0,00	0,00	0,00
1250	0,58	-0,06	0,60	0,00	-0,02	-0,06
1600	0,98	-0,06	1,00	-0,10	-0,02	0,04
2000	1,20	-0,18	1,20	-0,20	0,00	0,02
2500	1,28	-0,28	1,30	-0,30	-0,02	0,02
3150	1,26	-0,40	1,20	-0,50	0,06	0,10
4000	1,10	-0,68	1,00	-0,80	0,10	0,12
5000	0,78	-1,06	0,50	-1,30	0,28	0,24
6300	0,20	-1,64	-0,10	-2,00	0,30	0,36
8000	-0,60	-2,46	-1,10	-3,00	0,50	0,54
10000	-1,74	-3,62	-2,50	-4,40	0,76	0,78
12500	-3,30	-5,14	-4,30	-6,20	1,00	1,06
16000	-5,48	-7,32	-6,60	-8,50	1,12	1,18
20000	-7,90	-9,74	-9,30	-11,20	1,40	1,46

Table 3.12: A- and C-weighted frequency response

3.8 Verifiable Firmware

Tango_Plus is verifiable with the firmware version 2.51. The version can be checked via: Functions > Device > Info.



Figure 3.13: Display of verifiable firmware version with lock symbol

NOTICE!

If the firmware is verified, it will be indexed in the display with a lock symbol. An update by subsequent versions is not possible!

4 Technical specifications

Property	Value
Software	Tango-Utilities
Number of channels	1
Accuracy	Class 1 according to IEC 61672-1:2014
Display of measured values	Colour TFT 320 x 240
Display refresh rate	500 ms
Frequency weighting	A, C (simultaneously), no optional frequency weightings
Time weighting	Fast, Slow, Peak (simultaneously), Impulse
Data storage	Yes
Self-generated noise	≤ 14 dB(A), ≤ 16 dB(C)
Max. Sound Pressure Level	see table 4.3
Linearity range	25... 140 dB(A) (at 1 kHz)
Nominal measuring range for L_{Cpeak}	37... 143 dB(C)
Max. electr. measuring range	± 2 V
Max. input voltage at the input of the feeding device	$\pm 2,5$ V
U_{max} at input	$\pm 2,5$ V
Integration response	immediate
Time weighting F	Rise or decay time constant = 0.125 s
Time weighting S	Rise or decay time constant = 1 s
Time weighting Peak	Rise time constant = 20 μ s
Time weighting Impulse	Rise time constant = 0.035 s, decay time constant = 1.5 s
Shortest integration time	16 ms
Longest integration time	194 days (100 h running on rechargeables)
Interfaces	USB-C, serial printer port, 3.5mm stereo jack
Stabilizing time after switch-on	1 min
Warm-up time	1 min
Calibration frequency	1 kHz
Max. time of day drift	max. 1.73 s in 24 h
Battery	2 x LR6/AA, 40 operation hours
External power supply	via USB (see accessories)
Dimensions	266 mm x 76 mm x 38 mm
Weight	320 g (batteries inserted)
Reference conditions	
Reference direction	Handheld: 0 °, Outdoor: 90 °
Reference sound pressure level	94 dB
Reference frequency	1 kHz
Reference measuring range	25... 140 dB(A)
Reference air temperature	23 °C
Reference air pressure	101.325 kPa
Reference relative humidity	50 %

Table 4.1: Technical data Tango_Plus

According to IEC 61672-1:2014 Tango_Plus has been tested under the following conditions:

Property	value
Frequency range (Free field frequency response)	20 Hz bis 20 kHz
Level range	section 3.6.1
Restriction of linear level range due to mechanical vibration	section 3.4.1
Temperature range	-10 °C bis 50 °C
Static air pressure	65 kPa bis 108 kPa
Relative humidity	25 % bis 80 %
Electrostatic discharge	section 3.3.2
High frequency fields	section 3.3.4
Mechanical vibration	section 3.4.1
Apply signal via equivalent capacitance	K65 (Microtech Gefell)

Table 4.2: Test conditions for Tango_Plus

4.1 Microphone with capsule MK255

Only the original microphone capsule MK255 by MICROTECH GEFELL is approved for measurements with Tango_Plus. Data specific for configuration can be found in the sections 3.1 and 3.2. The acoustic center point and microphone reference point are located at the middle of the microphone membrane.

Property	Value
Model Transducer type	Capacitive pressure transducer
Polarization	backelectret
Frequency range free-field	3.5 Hz ... 20 kHz (± 2 dB)
Sensitivity	ca. 50 mV/Pa
Max. SPL for 3 % , distortion at 1 kHz	146 dB
Self-generated noise with preamplifier	15 dBA
Capacitance	17 pF
Operating temperature range	-50 ... +100 °C
Ambient temperature coefficient	$leq 0.01$ dB/°C
Ambient pressure coefficient	-0.01 dB/kPa
Diameter	1/2"
with protection lid	$13,2 \pm 0,02$ mm
without protection lid	$12,7 \pm 0,02$ mm
Length	16,4 mm
Weight	7,5 g
Thread for preamplifier	11,7 mm 60 UNS
Thread for protection	12,7 mm 60 UNS

Table 4.3: Technical data MK255

4.1.1 Random incidence and free-field correction

f in Hz	Free field cor. in dB	Diffuse field cor. in dB	f in Hz	Free field cor. in dB	Diffuse field cor. in dB
25	0	0	0.8 k	0	0
31.5	0	0	1 k	0	0
40	0	0	1.25 k	-0.03	0
50	0	0	1.6 k	0.03	0
63	0	0	2 k	0.21	-0.1
80	0	0	2.5 k	0.36	-0.1
100	0	0	3.2 k	0.56	0
125	0	0	4 k	0.88	0.1
160	0	0	5 k	1.36	0.2
200	0	0	6.3 k	2.01	0.4
250	0	0	8 k	2.99	0.7
315	0	0	10 k	4.25	0.9
400	0	0	12.5 k	6.14	1.8
500	0	0	16 k	8.77	3.4
630	0	0	20 k	9.9	3.2

Table 4.4: Free-field and random incidence corrections (manufacturer's specification: measurement uncertainty at 95% certainty ± 0.6 dB)

4.1.2 Connection assembly of the detachable microphone

The microphone of Tango_Plus is detachable and connected to the analyser via LEMO plug FGG.1B.307 in case FGC.1B.110.CZZ. The pin assignment is shown in figure 4.1.

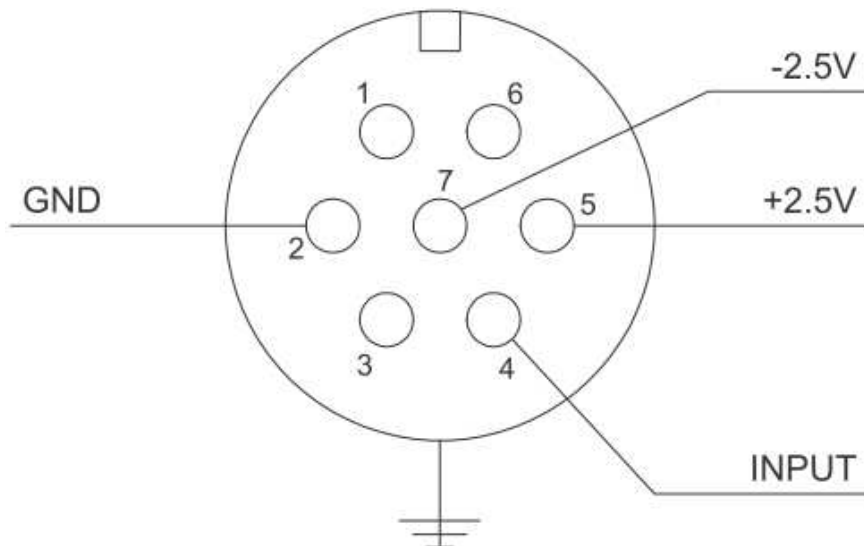

Figure 4.1: Pin assignment for the detachable microphone

ATTENTION! The detachable microphone must be used only with the matched Tango_Plus! Otherwise warranty is lost and it may be damaged.

4.2 Optional Accessories

Optional Accessory	Manufacturer	Item number
Cal200	PCB, 1 kHz, 94 dB or 114 dB	800934.4
Type 4231	B&K, 1 kHz, 94 dB bzw. 114 dB	800043.2
USB power supply adaptor	SINUS Messtechnik GmbH	601092.6

Table 4.5: Available accessories for Tango_Plus

4.3 Technical specifications of the calibrators

Feature	Value
Standards	IEC 60942:2003 and IEC 60942:2017 and ANSI S1.40-2006, Class 1
Sound pressure level	94 dB, 114 dB \pm 0.2 dB
Supported microphone types	1/2" with adapters for: 1/4", 3/8", 1/8"
Weight	156 g
Sound pressure stability	<0.1 dB
Surrounding conditions	
Static pressure	65 kPa ... 108 kPa
Humidity	10% ... 90% RH
Temperature	-10 °C ... + 50 °C

Table 4.6: Technical specifications Cal200

Feature	Value
Standards	IEC 60942:2003 and ANSI S1.40-2006, Class 1
Sound pressure level	94 dB, 114 dB \pm 0.2 dB
Supported microphone types	1" with adapters for: 1/2", 1/4", 1/8"
Weight	approx. 150 g
Sound pressure stability	<0.05 dB
Surrounding conditions	
Static pressure	65 kPa ... 108 kPa
Humidity	10 % ... 90 %RH
Temperature	-10 °C ... + 50 °C

Table 4.7: Technical specifications Type 4231

5 Declaration of Conformity

We, **SINUS Messtechnik GmbH**, Foepplstrasse 13, 04347 Leipzig, Germany, declare that the product

Sound Level Meter Tango_Plus

Part Number: 907004.2

Serial Number:

to which this **CE**-declaration relates, is in conformity with the following standards and other documents:

Technical Parameters	Sound Level Meter:	IEC 61672 or DIN EN 61672-1:2014 DIN EN 45657
	Third-octave analyzer:	DIN EN 61260:2003 class 1
Electromagnetic Compatibility:	Emission	IEC 61000.6.3 or DIN EN 61000-6-3 IEC 61672 or DIN EN 61672
	Immunity	IEC 61000.6.2 or DIN EN 61000-6-2 IEC 61326 or DIN EN 61326 IEC 61672 or DIN EN 61672
Safety		IEC 61010.1 or DIN EN 61010-1

The measuring system is intended for use with measuring microphones according to IEC 1094-1. This product has been manufactured and tested in compliance with the following binding internal documentation from SINUS Messtechnik GmbH:

Manufacturing and Testing documents:	- Quality assurance manual - Manufacturing documents for Tango_Plus - Testing rules for Tango_Plus
--------------------------------------	--

This product was tested and found to comply with all specifications.

Gunther Papsdorf
Managing Director

Index

C	
Calibration	21
Calibrated Measurement	23
Start button	14
Calibrator	45
Configuration	12
D	
Deactivate Panels	13
Delete	13
Directional characteristics	
Outdoor Kit	33
SLM	26
E	
EMC	38
Environmental conditions	39
Equivalent impedance K65	37
Erase	13
Export	19
Export directory	14
F	
First use	9
Frequency response	
Electrical test	37
Outdoor Kit	32
SLM	25
Frequency weighting	41
H	
Help	15
I	
Info	15
K	
K65	37
L	
Level linearity range	40
M	
Marker	14
Measure	23
Calibrated Measurement	23
low sound levels	23
O	
Operating Modes	12
OFF	12
Pause	12
Repeat Interval	12
Repeat mode	12
Run	12
Start Time	12
Stop	12
Operating range	40
P	
Power supply	6
Print measurement results	24
Program Settings	14
R	
Reference conditions	42
S	
Self-generated noise	40
Setup	
Display	15
Printer	15
Storage	15
Software installation	11
Sound level values	10, 25
Status Bar	14
Storage Requirement	14
T	
Testing information	25
Electrical test	37
EMC test	38
Type approval	
Approved parts	25
V	
Verifiable Firmware	41
View measurement results	24

